

# MANUAL

## Digital fire detection control panel COMPACT LYON



cofem, s.a.  
1973



## Index

1- System description .....	6
1.1- Introduction .....	6
1.2.- Principle of operation .....	6
1.3.- Characteristics .....	7
1.4.- Composition of the control panel .....	7
1.5. – Loop Elements Capacity .....	8
1.5.1.- Analogue sensors.....	12
1.5.1.1.- Analogue smoke sensors (A30XHA y A30XHAS).....	12
1.5.1.2.- Analogue temperature sensor (A30XTA).....	13
1.5.1.3.- Analogue multi-sensor (A30XHTCO) .....	14
1.5.2.- Analogue alarm Manual Call Point (PUCAY) .....	16
1.5.3. - Modules.....	17
1.5.3.1- Master detection module (KMAY).....	17
1.5.3.2- Master relays module (MDA1Y).....	18
1.5.3.3- Master relay module (MDA2Y) .....	18
1.5.3.4- Technical signals module (MSTAY).....	20
1.5.3.5- Loop isolator (KABY).....	21
1.5.3.6- Addressable sounder (SIRAY / SIRAYL / SIRAY+BSLC).....	22
1.5.3.7- Master relay and technical signals module (MYOA) .....	24
1.5.4- Repeaters .....	25
1.5.4.1- Installation .....	25
1.5.4.2- Operation and Configuration .....	25
1.5.4.3- Repeater menus .....	26
1.5.5- Control panel network .....	28
1.5.5.1- Installation .....	28
1.5.5.2- Operation and configuration .....	28
1.5.5.3- Control panels network menu.....	29
1.6- Accessories.....	30
1.6.1- PC Keyboard .....	30
1.6.2- PC based configuration software.....	30
2- Installation.....	30
2.1- Control panel installation. ....	30
2.2- C-Lyon system connection.....	31
2.2.1- Electrical supply network .....	31
2.2.2- Loop driver .....	32
2.2.3- Power supply auxiliary outputs and charging of power source batteries.....	32
2.3- Components.....	34
2.3.1- Batteries.....	34
2.3.2- Connection schematic of a typical loop.....	34
2.3.3- Sounder and controls with relays.....	36

2.3.3.1-	Connection of the internal two tone 24V Sounder (SIR-24B / SIR-24BL)	36
2.3.3.2-	Connection of the non-flashing internal 24V Sounder (SIR24P)	36
2.3.3.3-	Connection of the flashing internal 24V Sounder (SIR24F)	37
2.3.3.4-	Connecting the external 24V alarm box (CAE-PL)	37
2.4-	Accessories	38
2.4.1-	PC keyboard	38
2.4.2-	Computer	39
3-	Operation and configuration	41
3.1-	Description of the front panel	41
3.1.1-	Keypad	41
3.1.2-	Light indicators	41
3.1.3-	Screen	42
3.2-	Access levels	42
3.2.1-	Level 1 access	45
3.2.1.1-	Activation of the control panel	45
3.2.1.2-	Incident and anomaly display	46
3.2.1.3-	Moving through incidents	48
3.2.1.4-	Look up incidents	49
3.2.1.5-	Silence buzzer	49
3.2.2-	Level 2 access	49
3.2.2.1-	Access code	49
3.2.2.2-	Front panel keypad	49
3.2.2.3-	Reset events	49
3.2.2.4-	Monitor	49
3.2.2.5-	Activate / Deactivate logical relays	50
3.2.2.6-	Activate / Deactivate general relays	50
3.2.2.7-	System configuration	50
3.2.2.8-	Enable/ Disable elements and zones	50
3.2.2.9-	System test	50
3.2.2.10-	Welcome message	51
3.2.2.11-	General reset	51
3.2.2.12-	Review history	51
3.2.3-	Level 3 access	52
3.2.3.1-	Access code	52
3.2.3.2-	Label elements	52
3.2.3.3-	Configure	52
3.2.3.3.1-	Loop configuration	52
3.2.3.3.2-	Configure logical relays	53
3.2.3.3.3-	Configure alarm zones	54
3.2.3.3.4-	Configure element sensitivity	54
3.2.3.3.5-	Additional passwords	54
3.2.3.3.6-	Configure auto-evacuation	54
3.2.3.3.7-	Added Delay Setup	55
3.2.3.3.8-	Fast Trigger Zone	55

3.2.3.3.9- Send Zones to Repeaters.....	55
3.2.3.4- Update date and time. ....	55
3.2.3.5- Day/ Night times.....	55
3.2.3.6- Put into test/ normal mode.....	55
3.2.3.7- Led ON / OFF.....	56
3.2.3.8- Language menu. ....	56
3.2.3.9.- Communications.....	56
3.2.3.10.- Stop Sounder Function. ....	57
4- Set-up. ....	57
4.1- Prior verifications. ....	57
4.2- Supply.....	58
4.3- Loops and relays.....	59
4.4- Faults.....	59
Annex 1: Use of the Control Panel LYON / C-LYON / ZAFIR system .....	65
1. What is a control panel LYON / C_LYON /ZAFIR SYSTEM?.....	65
2. Front panel of the system.....	65
3. What happens if the buzzer sounds?.....	65
4. Checking the incident.....	65
5. Evacuation .....	66
6. SILENCE SIRENS .....	66
7. RESET EVENTS.....	66
Annex 2: Elements configuration Lyon / C-Lyon / Zafir .....	67
1. Introduction .....	67
2. Keypad access.....	67
3. Configuration of points in a loop.....	68
3.1. System Programming.....	69
3.2. Configure .....	69
3.3. Configure Loop.....	69
3.4. Loop Configuration.....	69
3.5. Assign a number to Point.....	70
4. Programming verification process.....	70
5. Configure Zones .....	70
6. Replacing a loop element.....	71

**CERTIFICATION**



**cofem**,

Crta. Molins de Rei a Rubí, Km 8,4 CP 08191 Rubí, Barcelona (España)

10 / 09

0099/CPR/A74/0102 – 0099/CPR/A74/0082

<p align="center"><b>EN 54-2</b></p>	<p align="center"><b>EN 54-4</b></p>
<p align="center"><b>Equipo de control e indicación para sistemas de detección y alarma de incendios de edificios</b></p> <p align="center"><b>Control and indicating equipment for fire detection and alarm systems in buildings</b></p> <p align="center"><b>“Compact Lyon”</b></p>	<p align="center"><b>Equipo de suministro de alimentación para sistemas de detección y alarma de incendios de edificios</b></p> <p align="center"><b>Power supply equipment for fire detection and alarm systems in buildings</b></p> <p align="center"><b>“C DFA-03”</b></p>
<p>Comportamiento frente a incendios <i>Performance under fire condition</i></p> <p align="right"><b>Cumple/ Passed</b></p>	<p>Comportamiento de suministro de alimentación/ <i>Performances of Power Supply</i></p> <p align="right"><b>Cumple/ Passed</b></p>
<p>Intervalo de respuesta (tiempo de respuesta al fuego) <i>Response delay (response time to fire)</i></p> <p align="right"><b>Cumple/ Passed</b></p>	<p>Fiabilidad en el funcionamiento/ <i>Operational reliability</i></p> <p align="right"><b>Cumple/ Passed</b></p>
<p>Seguridad Operacional <i>Operational reliability</i></p> <p align="right"><b>Cumple/ Passed</b></p>	<p>Duración de la seguridad operacional y retardo a la respuesta; resistencia a la temperatura <i>Durability of operational reliability, Temperature resistance</i></p> <p align="right"><b>Cumple/ Passed</b></p>
<p>Duración de la seguridad operacional y retardo a la respuesta; resistencia a la temperatura <i>Durability of operational reliability, Temperature resistance</i></p> <p align="right"><b>Cumple/ Passed</b></p>	<p>Duración de la seguridad operacional y retardo a la respuesta; resistencia a la vibración <i>Durability of operational reliability Vibration resistance</i></p> <p align="right"><b>Cumple/ Passed</b></p>
<p>Duración de la seguridad operacional y retardo a la respuesta; resistencia a la vibración <i>Durability of operational reliability Vibration resistance</i></p> <p align="right"><b>Cumple/ Passed</b></p>	<p>Duración de la seguridad operacional y retardo a la respuesta; estabilidad eléctrica <i>Durability of operational reliability: electrical stability</i></p> <p align="right"><b>Cumple/ Passed</b></p>
<p>Duración de la seguridad operacional y retardo a la respuesta; estabilidad eléctrica <i>Durability of operational reliability: electrical stability</i></p> <p align="right"><b>Cumple/ Passed</b></p>	<p>Duración de la seguridad operacional y retardo a la respuesta; resistencia a la humedad <i>Durability of operational reliability: humidity resistance</i></p> <p align="right"><b>Cumple/ Passed</b></p>
<p>Duración de la seguridad operacional y retardo a la respuesta; resistencia a la humedad <i>Durability of operational reliability: humidity resistance</i></p> <p align="right"><b>Cumple/ Passed</b></p>	<p align="right"><b>Cumple/ Passed</b></p>

**Compact Lyon control panels are supplied with the following material:**

- 2 end of line resistances 4K7 2W 5%
- 2 diodes DBY252
- 4 fuses: 1 A, 2 A, 4 A y 8 A.

## 1- System description

### 1.1- Introduction

The Digital Fire detection Control Panel **Compact Lyon** is EN54-2 and EN 54-4 standard certified according to the latest CE directives and can successfully overcome difficult environmental conditions, electrical interference, electromagnetic radiate upsets, vibrations, etc.

The **Digital Detection System** represents the most modern technology in fire detection and constitutes a natural evolution from the Identifiable Detection System towards equipment that not only is able to identify the element that produces the alarm (sensor or button), but that also allows for the total configuration of detection parameters (alarm levels, sensitivity,...) as well as the adaptation of the set-up to the environmental conditions and the dirtiness of the sensor.

In the Cofem Digital Detection System, the loop elements (sensors, manual call points, relay modules, masters, analogue sounders and technical indicator modules) are auto-identifiable, in other words, all of them can be installed with no need for prior manual encoding, facilitating enormously the assembly of and subsequent modifications to the installation.

### 1.2.- Principle of operation

The **Digital Detection System** is based on the measurement and transmission of the instant value of the monitored magnitude (smoke, temperature or monoxide concentration), for their subsequent processing in the control panel, which will consider the alert or standby status of the sensor.

The temperature, the smoke concentration and the amount of monoxide are sent through the corresponding sensor in electrical voltages related to the measured magnitude.

After an adaptation process, an optimal relationship between the measured magnitude and the electrical voltage is obtained.

Each sensor incorporates a microprocessor responsible for the digitisation of the analogue value read in the sensor, for transmission of this value to the control panel and for identification of the sensor.

The main difference between the conventional and analogical detection systems lies in that for the former the Voltage delivered by the transducer is compared with a predetermined and fixed threshold ( $V_{alarm}$ ), obtaining from that comparison the *system in standby* or *system in alarm* status.

In the digital detection system, on the contrary, the value given by the transducer is constantly recorded and processed, being possible to act on the detection parameters, as well as, for example, the alarm threshold.

With this type of system, not only we can vary the sensitivity of the sensor, but we can even adapt the sensitivity to the environmental conditions.

Each sensor on the Cofem Digital Detection System transmits its digital value to the control panel with a regularity of less than 10 seconds. The control panel gathers the readings from each sensor and determines the status thereof according to these instant readings, any previous readings (history), the pre-programmed parameters and on the decision algorithm.

**Note:** Within the detection and fire alarm systems, there are 2 different technologies. In the CONVENTIONAL SYSTEM, the detector or the alarm call point is causing alarm in the control panel. In the ADDRESSABLE SYSTEM, the detector, the alarm call point or the module, is the device which communicates the value of reading or state to the control panel, and this one processes the alarm state

### 1.3.- Characteristics

- Base control panel of 1 or 2 loops.
- Allows 199 connection elements per loop.
- All the loop elements are monitored, except the **KABY** loop isolator.
- Capacity for up to 64 configurable relays.
- Enables programming of 99 zones.
- File that stores up to 4095 events with date and time.
- Monitored delayable general siren output identified as S1 **SIRENA** (Sounder).
- Voltage-free non-monitored alarm output identified as S1 **ALARMA** (Alarm).
- Non-monitored delayable free voltage general failure output identified as S3 **AVERIA** (Fault).
- Evacuation button.
- Backlit LCD display of 4 lines and 40 characters.
- Incorporates Spanish, English, French, Portuguese, etc).
- Configurable and manageable through I-Link PC software.
- Allows connection to an external keyboard (PC standard – PS2).
- Allows connection of up to 15 repeaters and 15 control panels in network.
- Contact ID (See specific manual of this functionality).
- Cofem Remote on demand
- Size: 363 x331 x 96 mm
- IP30.
- Certified and CE mark according to EN 54-2 and EN 54-4 Standard.

### 1.4.- Composition of the control panel

- Backlit LCD display of 4 lines and 40 characters.
- Keyboard made up of 13 keys that form two groups; one where the menu handling keys can be found and the other where specific control panel functions may be performed.
- 15 LEDs that enable quick viewing of the control panel status (Supply, Mode of operation, Alarms and Failures).
- Communications port: RS485 and USB 2.0.
- Power supply: independent module responsible for controlling the Voltage of the primary 30V supply that supplies the other boards. There are inside: protection fuses, 30 V output, battery connection terminals, relay outputs:
  - **S1 SIRENA:** Sounder: delayable monitored relay.
  - **S2 ALARMA:** Alarm: Voltage-free relay.
  - **S3 AVERÍA:** Failure: monitored free voltage delayable relay
- Multitasking CPU: within the CPU there are a loop controller, a power controller, two-loop driver, communication port 485 and USB 2.0 compatible.

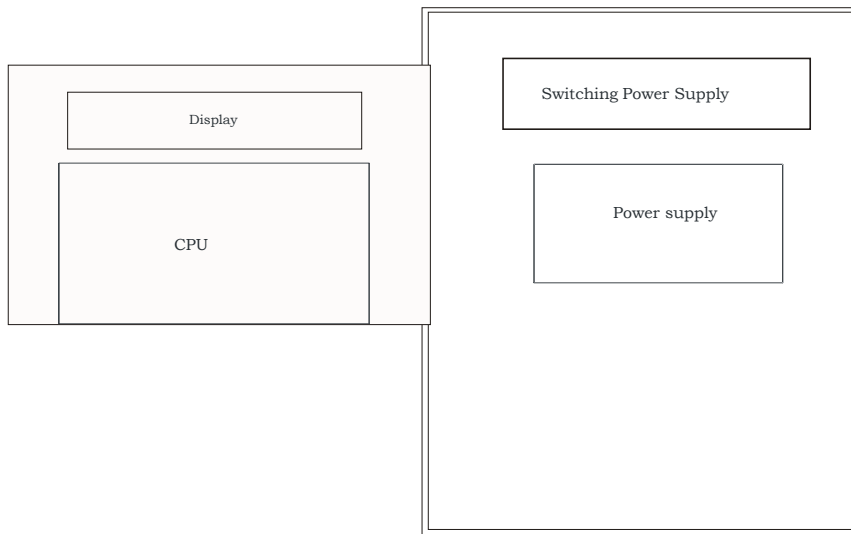

**Figure 1.** Layout of circuits in the control panel

### 1.5. – Loop Elements Capacity

The number of devices that it is possible to connect to the loop is calculated of precise form by the software of loop elements capacity calculation.

When it is not feasible to use the previous software, it can be used next table to obtain approximate capacity, which, in a general way, gives values under the real performances of the system.

For this motive, it is necessary to check real capacity of the system by means of the loop elements capacity calculation software when results of using table approximation doesn't allow to satisfy the installation necessities, as the real capacity of the system can be higher than expected by the tables.

To calculate the capacity of the system, it should take into account two parameters: The number equivalent elements connected in the loop (shown in the table depending on cable length, cable section and control panel model) and number of logic relays (also shown in the table).

The system will work properly when it meets the limits established in the device limit per control panel.

For the system, the cable length is the length of the loop cable from the nearest element in the loop to the control panel, measure to the other side of the control panel loop input/output. That means length cable is always less that the cable length loop as it is shown in the figure.

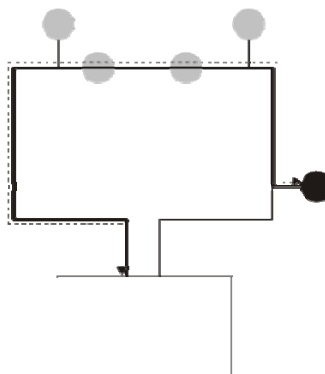

The cable material for the table is Cu with  $41 \Omega \cdot \text{mm}^2/\text{Km}$ , as it is stated in the corresponding note.





Device Limits per Control Panel									
Reference	Description	Logic Relays	LYON & ZAFIR control panel				C-Lyon Control Panel		
			Loop limit	Element equivalence		Cable section	Loop limit	Element equivalent	Cable section
A30XHA	Addressable optical-thermal sensor	---	Cable lenght -> 199	≤ 800 m	≤ 500 m	2x1,5 mm <sup>2</sup>	Cable lenght -> 99	≤ 800 m	2x1,5 mm <sup>2</sup>
A30XHAS	Addressable optical sensor	---	199	≤ 1350 m	≤ 850 m	2x2,5mm <sup>2</sup>	99	≤ 1350 m	2x2,5mm <sup>2</sup>
A30XHTA	Addressable thermal sensor	---	199	1	1		99	1	
A30XHTCO	Optical-thermal-monoxide Multisensor	---	199	1	1		99	1	
PUCAY	Addressable Manual Call Point	---	199	2	1		99	1	
MSTAY	Technical signal module	---	99	3	3		57	2	
KMAY	Conventional zone master module	---	99	5	3		72	2	
MYOA	Relay and technical signal module	1	32	5	3		31	2	
MDA1Y	Relay module	1	32	5	3		32	2	
MDA2Y	Relays module	2	16	5	3		16	2	
KABY	Loop isolator	---	199	1	1		99	0	
SIRAY	Addressable sounder	1	32	8/16 <sup>A</sup>	6/12 <sup>A</sup>	4/8 <sup>A</sup>	32	4/8 <sup>A</sup>	
SIRAYL	Addressable sounder with light	1	32	10/20 <sup>A</sup>	8/14 <sup>A</sup>	6/10 <sup>A</sup>	25	6/10 <sup>A</sup>	
SIRAY+BSLC	Addressable sounder with EN 54-23 light	1	19	25/35/40 <sup>B</sup>	16/24/26 <sup>B</sup>	12/20/22 <sup>B</sup>	10	12/20/22 <sup>B</sup>	
<b>Control panel limits:</b>									
<b>LYON control panel</b>			<b>ZAFIR control panel</b>				<b>C-Lyoncontrol panel</b>		
a) 199 elements with 32 logic relays per loop, and b) 20 loops with 199 logic relays			a) 199 elements with 32 logic relays per loop				a) 99 elements with 32 logic relays per loop		
<p><sup>A)</sup> Values correspond with the standard/maximum sound intensity of the sounder.</p> <p><sup>B)</sup> Value corresponds with the sound-light standard/ sound <b>or</b> light at maximum/ sound <b>and</b> light at maximum, sounder intensity</p> <p>Note: The cable is considered with resistance of 32,9 Ω/Km * mm<sup>2</sup> (Copper cable).</p>									

### EXAMPLE OF CALCULATION

An installation requires 136 A30XHAS sensors, 17 PUCAY manual call points and 18 addressable sounders SIRAY with standard sound level.

It is known that installation requires 1 loop cable of 500 m with 2x1,5 mm<sup>2</sup> section, where the nearest device to control panel is 50 m.

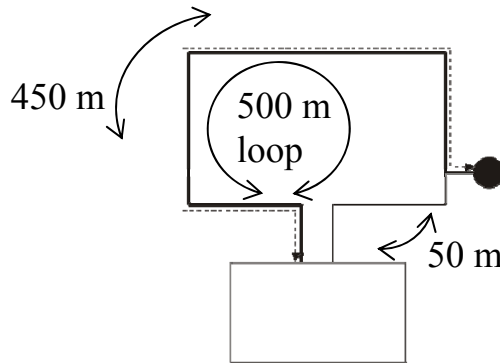

First, it is made calculation using table of device limits per control panel, with a C-Lyon control panel, 2x1,5 mm<sup>2</sup> section, and cable length  $\leq 500$  m (for this case, cable length is 450 m). Following table is obtained:

Devices in installation	Elements equivalence according to table	Elements consumption	Relays equivalence according to table	Relays consumption
72 A30XHAS	1	72	-	0
9 PUCAY	1	9	-	0
10 SIRAY	4	40	1	10
<b>TOTAL</b>				
<b>91 Elements</b>	-	<b>121 Elements</b>	-	<b>10 Relays</b>

Comparing these results with the boundaries of the control panel at the device limits of control panel, we get:

	Control panel Lyon	Calculation	RESULTS
Loop elements consumption	99	121	<b>99 &lt; 121 → EXCESS</b>
Relays limits	32	10	<b>32 ≥ 10 → Ok</b>

The limit of loop elements consumption of control panel is 199 elements. Calculation gets 121 elements, therefore, capacity of the loop is exceed.

Now, calculation will be accurately made by the software of loop elements capacity calculation.



LOOP ELEMENTS CAPACITY CALCULATION CÁLCULO DE CAPACIDAD DE ELEMENTOS DEL BUCLE	
GENERAL DATA/ DATOS GENERALES	
Control Panel Model/Modelo Central =	C-Lyon
Wire length /Longitud del cable =	450 m
Cable section/Sección del cable =	1,5 mm <sup>2</sup>

LOOP ELEMENTS DATA/ DATOS ELEMENTOS BUCLE				
Nº Elements/ Nº Equipos	Model / Modelo	Sound dB/ Sonido dB	Power Light/ Potencia Luz	
9	PUCAY			
0	KMAY			
0	MSTAY			
0	MDA1Y			
0	MDA2Y			
0	MYOA			
72	A30XHA/A30XHAS/ A30XTA/A30XHTCO			
0	KABY			
10	SIRAY	Standard		
0	SIRAYL	Standard		
0	(SIRAY + BSLC)	Standard		Standard

RESULTS/ RESULTADOS	
LOOP LOAD/ CARGA DEL BUCLE =	83,95%
Nº Elements / Nº Elementos =	91
Nº Relays/ Nº Relés =	10

It is shown the results. Loop of control panel C-LYON perfectly support this configuration instead of calculation by table of device limits per control panel were excess of capacity.

This example clearly states that it is important to check results by software of loop elements capacity calculation when it is obtained excess performances by using the table of device limits per control panel.

It also could have achieved this result using the software directly.

## 1.5.1.- Analogue sensors

### 1.5.1.1.- Analogue smoke sensors (A30XHA y A30XHAS)

The analogue smoke sensors measure the smoke particle concentration by unit of volume present in the atmosphere. If we designate by  $Y$  an un-dimensioned parameter proportional to the smoke concentration, then  $Y$  will have to be close to zero, and will be growing as the atmosphere is contaminated.

The implemented dynamic processing algorithms in the control panel, use the  $Y_{\text{alarm}}$  value as level for setting off the Alarm. This preset level is at:

$$Y_{\text{alarm}} = 40$$

This level can be manually modified from the control panel.

When the concentration of smoke exceeds the **Alarm Level** (the average must exceed  $Y_{\text{alarm}}$ ) the alarm for the sensor is activated.

Through the control panel, a level  $Y_{\text{dirty}}$  (20) is set and when this is exceeded the system warns us of the need to replace or repair the sensor.

The Optical Smoke Sensor (A30XHA) is based on the Tyndall effect created in an optical camera. The variation of the electrical characteristics in the presence of combustion aerosols makes it suitable as a smoke sensor.

The sensor element is formed by an optical camera provided with an infrared emitter and receiver. In the absence of smoke the intensity of infrared caught by the receiver is null, due to the physical labyrinth created between the two. When smoke is present, the infrared reflections from the particles of the same cause the receiver to obtain a certain luminance intensity, (Voltage value proportional to the level of obscuration), all of which is controlled by the microprocessor system.

This sensor has a thermistor, acting as a temperature sensor, triggering at 60°C, considerably augmenting its response to fire.

An optical smoke sensor without a thermal element is also available, with reference **A30XHA-S**.

The **A30XHA** and **A30XHA-S** are conformant with EN 54-7 with the conformity mark awarded by AENOR.

The head and the base (interchangeable throughout the range of sensors) are made in thermal resistant ABS.

The flashing of the red transparent LEDs indicates communication with the Control panel C-Lyon system, and if they remain lit they indicate the alert status of the sensor.

Connection is made according to figure 2.



Sensor A30XHA



Sensor A30XHAS

Technical specifications A30XHA and A30XHA-S	
Supply	24 – 35 V any polarity
Standby consumption	1 mA
Alarm consumption	5 mA
Indicator activation	Double red LED
Remote indicator output	Yes
Humidity	20% – 95% RH
Temperature	-10° + 50°C
Sensitivity	According to EN 54-7
IP	IP40

### 1.5.1.2.- Analogue temperature sensor (A30XTA)

The Analogue Temperature Sensor (A30XTA) measures the room temperature, as well as its rate of change.

When the ambient temperature experiences slow rates of change (less than 1°C / min), the Alarm level remains constant to 60°C. However, for fast variations in temperature (above 1 °C/min), the control panel uses an algorithm capable of evaluating the rate of change of temperature, and of adjusting the Alarm level to different gradients (*rate of rise detection of temperature*). In this way, a fast variation causes a decrease in the Alarm threshold, thereby accelerating the detection.

The chosen degree of sensitivity will depend on the room temperature of the place where each sensor is installed, and in each case the alarm temperature will adapt to the chosen degree.

Also in the detection of temperature confirmation by means of two consecutive readings is used (less than 10 seconds), before activation of the Alarm.

The operation principle is based on the physical properties of an NTC. The variation in electrical characteristics of the thermistor, due to the variation of the room temperature, is what enables its use as a sensor element.

The measurement made by the sensor is converted in a Voltage value, which is digitized and transmitted to the control panel.

The **A30XTA** is conforms to EN 54-5 with the mark of conformity with the regulations awarded by AENOR with an A2R sensitivity degree.

The head and the base (interchangeable throughout the range of sensors) are made in thermal resistant ABS.

The flashing of the red transparent LED indicates communication with the Control panel C-Lyon system, and if they remain lit they indicate the alert status of the sensor.

Connection is made according to figure 2.



<b>Technical specifications A30XTA</b>	
Supply	24 – 35 V , any polarity
Standby consumption	1 mA
Alarm consumption	5 mA
Indicator activation	Double red LED
Remote indicator output	Yes
Humidity	20% – 95% RH
Temperature	-10° + 50°C
Sensitivity	According to EN 54-5
IP	IP20

### 1.5.1.3.- Analogue multi-sensor (A30XHTCO)

The analogue multi-sensor A30XHTCO has three detection types: monoxide, temperature and smoke.

The analogue multi-sensors is able to measure three types of parameters so the control panel calculates an average by means of a dynamic processing algorithm which will vary with the three phenomena. This processing algorithm will avoid false alarms to a great extent thanks to the incorporation of the monoxide sensor.

The processing algorithm is able to compensate for dirt on the optical camera by combining the measurements of the three different sensors.

The sensor element is formed by an optical camera provided with an infrared emitter and receiver. In the absence of smoke the intensity of infrared captured by the receiver is null, due to the physical labyrinth created between the two. When smoke is present, the infrared reflections from the particles of the same cause the receiver to obtain a certain luminance intensity, (Voltage value proportional to the level of obscuration), all of which is controlled by the microprocessor system.

In addition, it has a carbon monoxide sensor with a fast response in the presence of CO which is present in the vast majority of fires.

Finally this sensor has a thermal probe, acting as a thermal sensor, triggering at 60°C, considerably increasing its response to fire.

The **A30XHTCO** is conformant with EN 54-7 with the conformity mark awarded by AENOR.

The head and the base (interchangeable throughout the range of sensors) are made in thermal resistant ABS.

The flashing of the red transparent LEDs indicates communication with the Centralised C-Lyon system, and if they remain lit they indicate the alert status of the sensor.

Connection is made according to figure 2.



Technical specifications A30XHTCO	
Supply	24 – 35 V any polarity
Standby consumption	1 mA
Alarm consumption	5 mA
Indicator activation	Double red LED
Remote indicator output	Yes
Humidity	20% – 95% RH
Temperature	-10° + 50°C
Sensitivity	According to EN 54-7
IP	IP40

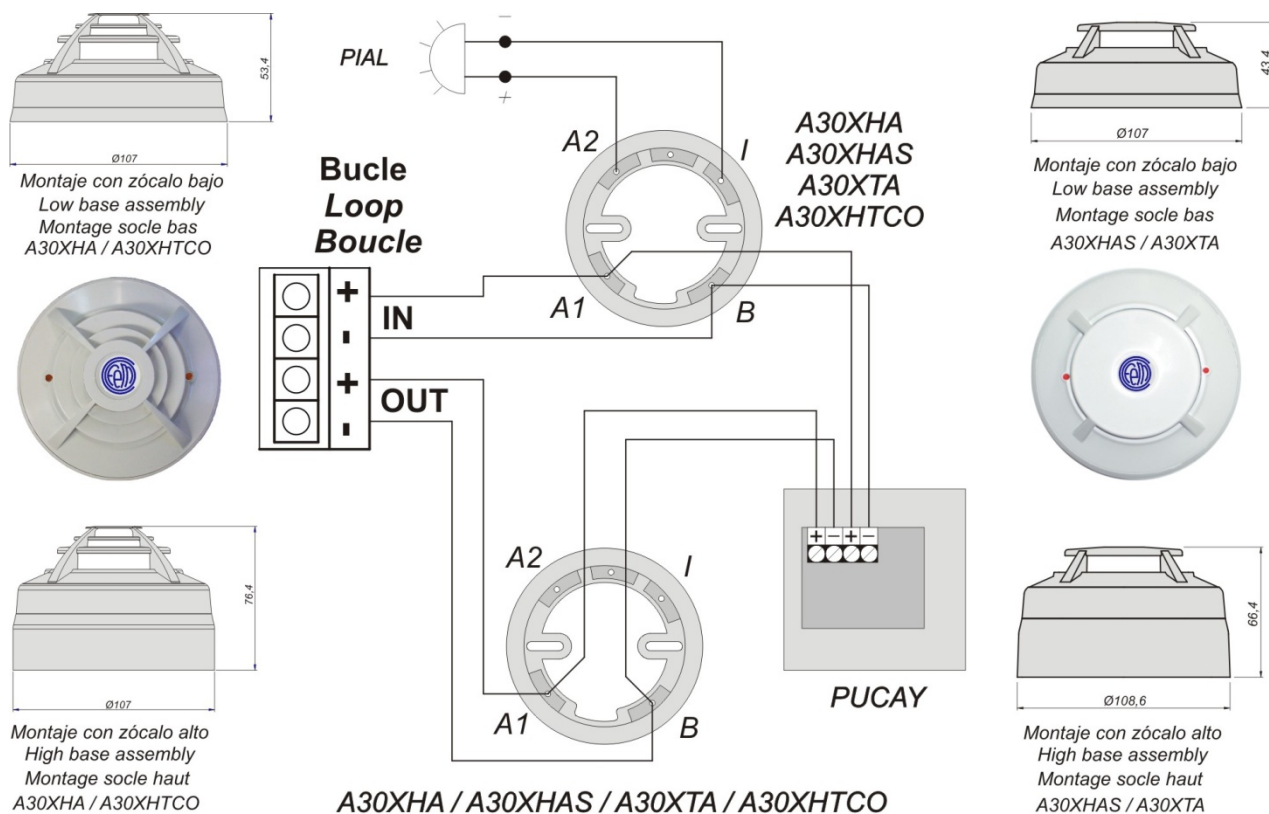

**Figure 2.** Connection schematic A30XHA, A30XHAS, A30XTA, A30XHTCO and PUCAY

### 1.5.2.- Analogue alarm Manual Call Point (PUCAY)

The re-settable Analogue and Addressable manual call point (with short-circuit isolator) incorporates an action indicator (LED) which is illuminated in the case of being manually activated (alarm).

The flashing of the transparent red LED indicates communication with the Control panel C-Lyon system, and if it remains on it indicates the alert status of the button.

There is a version “PUCAYEXT” that it is computed by control panel as the activation of 2 simultaneous devices. In this way, crossed relay L and crossed relay SL can be triggered directly when you push this PUCAYEXT. From loop device capacity, PUCAYEXT version is considered as a PUCAY.



The connection is made according to figure 2.

The PUCAY is conformant with EN 54-11 with the conformity mark awarded by AENOR.

**Note: To determine the number of PUCAY it can be installed, consult the devices limit per control panel table (Chapter 1.5).**

Technical specifications PUCAY	
Supply	24 – 35 V with polarity
Standby consumption	1 mA
Alarm consumption	5 mA
Indicator activation	red LED
Remote indicator output	No
Humidity	20% – 95% RH
Temperature	-10° + 50°C
IP	IP50



### 1.5.3. - Modules

#### 1.5.3.1- Master detection module (KMAY)

Microprocessed analogue and addressable device (with short-circuit isolator) installed as another element inside the loop.

This is a device that allows connecting conventional detectors and/or manual call point inside an analogue fire detection system, realising the interface function between the analogue detection system and the conventional one.

In the “Zona C” terminal, a maximum of 10 conventional call points can be installed. In the “Zona D” terminal, it is allowed 20 temperature detectors (A30XT, A30XV) or 15 elements between conventional smoke detectors (A30XH, A30XHS) and manual call points. Both terminals are monitored by an end of line capacitor, 10 µF/63V. In this way, it is indicated an open line, crossed line, alarm detector or alarm manual call point status.

The flashing of the transparent red LED indicates communication with the control panel, and if it remains on it indicates the alarm status of a detector or manual call point connected to this module.



This module has an output for activation of a remote indicator which will be activated when alarm status is reached. The Master Detection Module takes the power supply from the loop.

The Master Detection Modules is placed in a rectangular, heat-resistant ABS box.

The **KMAY** is conformant with EN 54-18 with the conformity mark awarded by AENOR. Connection is made according to figure 3.

**Note: To determine the number of KMAY it can be installed, consult the devices limit per control panel table (Chapter 1.5).**

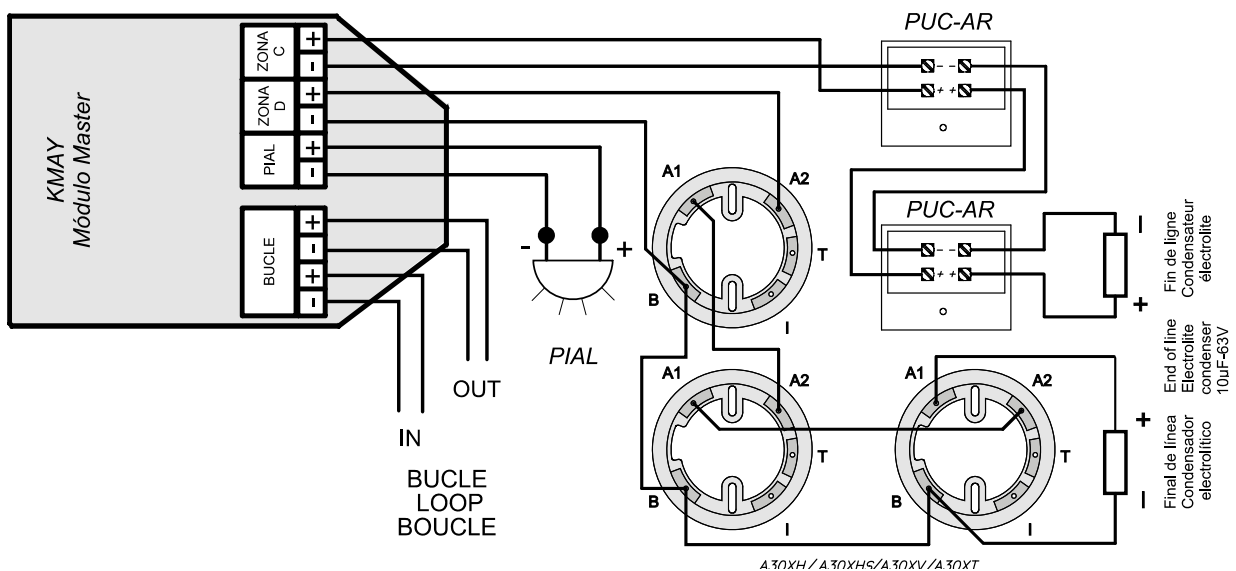

**Figure 3.** Connection schematic KMAY

### 1.5.3.2- Master relays module (MDA1Y)

Microprocessed analogue and addressable device (with short-circuit isolator) installed as another element inside the loop.

The Modules take the power supply from the loop, but they require an auxiliary 30V supply to give the necessary energy to the devices controlled by the relays. They monitor the presence of Voltage in the auxiliary supply line of 30V and in the output of the monitored relays. The Module is protected by 0.9 A resettable fuse and each monitored output by 0,5 A. The flashing of the transparent red LED indicates communication with the Lyon system. Illumination of the green LED indicates the actuation of a relay.

The device is placed in a rectangular, heat-resistant ABS box.

This is a module with two relay outputs of simultaneous activation (with a single function), not only in its type of application (sounder, switches or crossed relay), but also in their timing and in the combination of sensors that activate them. The R1 output relay is monitored with a line termination resistance of 33K $\Omega$ , indicating the state of opened line or crossed line. The R2 output relay acts as a dry contact NO and NC, not monitored, which typical application is the energising of the electromagnets of fire-resistant doors. Considering the consumption produced across the system, it is recommended installation of an External Power Supply when connecting more than 10 electromagnets altogether per detection system.

The **MDA1Y** is conformant with EN 54-18 with the conformity mark awarded by AENOR.

Connection will be made according to figure 4.

**Note: To determine the number of MDA1Y it can be installed, consult the devices limit per control panel table (Chapter 1.5).**



### 1.5.3.3- Master relay module (MDA2Y)

Microprocessed analogue and addressable device (with short-circuit isolator) installed as another element inside the loop.

The Modules take the power supply from the loop, but they require an auxiliary 30V supply to give the necessary energy to the devices controlled by the relays. They monitor the presence of Voltage in the auxiliary supply line of 30V and in the output of the monitored relays. The Module is protected by 0.9 A resettable fuse and each monitored output by 0,5 A. The flashing of the transparent red LED indicates communication with the Lyon system. Illumination of the green LED indicates the actuation of a relay.

The device is placed in a rectangular, heat-resistant ABS box.

It is a module with two relay outputs of independent activation (two functions), not only in their type of application (sounder, switches or crossed relay), but also in their timing and in the combination of sensors that activate them. In the standby state, the MDA2Y monitors both external line by means of a 33K $\Omega$  resistance, indicating the state of open line or crossed line.

The **MDA2Y** is conformant with EN 54-18 with the conformity mark awarded by AENOR.

Connection will be made according to figure 5.

**Note: To determine the number of MDA2Y it can be installed, consult the devices limit per control panel table (Chapter 1.5).**



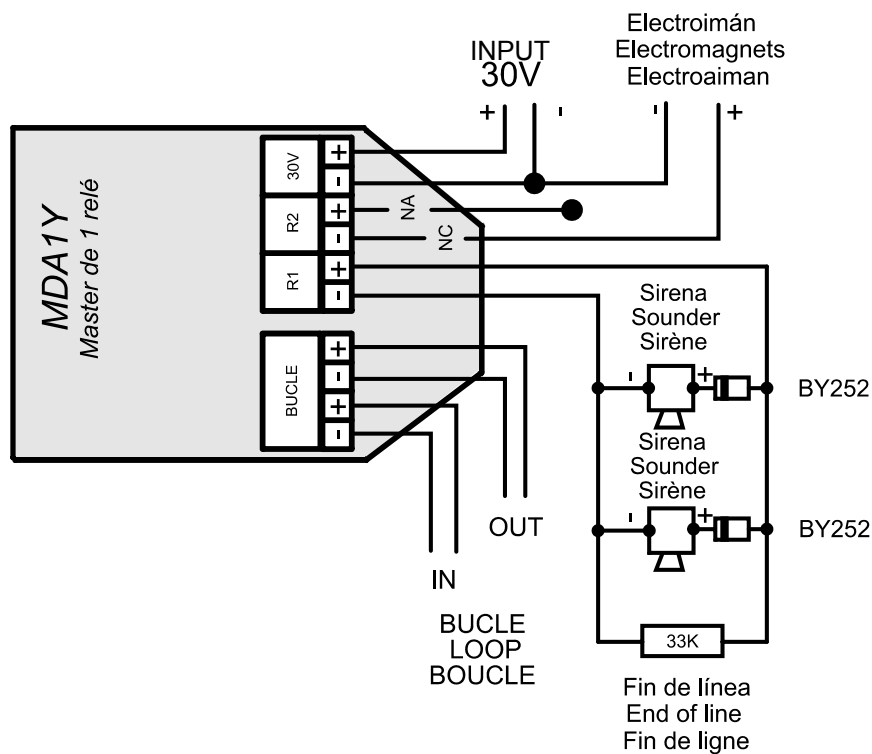

Figure 4. Connection Schematic

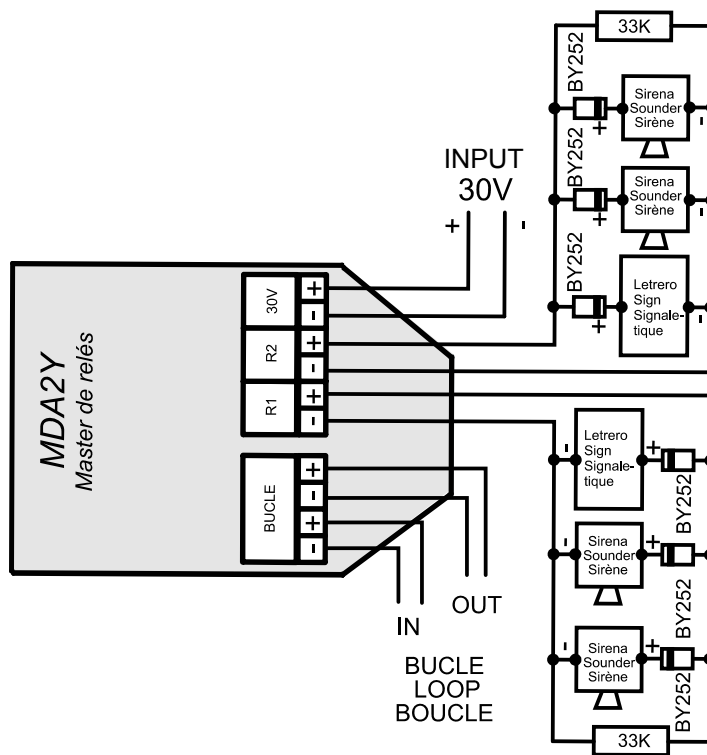

Figure 5. Connection Schematic

### 1.5.3.4- Technical signals module (MSTAY)

Microprocessed analogue and addressable device (with short-circuit isolator) installed as another element inside the loop.

It has two inputs to distinguish between the open or close state of a dry contact connected in series with a 10 KΩ resistor. In quiescent condition, the contact has to be open, and in anomaly condition, the contact has to be closed. In the first input (marked with IN1), the closed contact is detected as an ALARM condition. In the second input (marked with IN2), the closed contact is detected as FAULT Warning condition. It is possible to associate both inputs having an alarm and fault conditions information.

In the quiescent condition, the device supervises the electrical connection through a 33 KΩ resistor, which allows indication of open or closed electrical connection status.

It is typically used to signal the status of other detection systems that may exist, as for example, connection of flow sensors in the case of sprinkler installations, end of travel in the case of fire-resistant doors, elevators, level of deposits, etc.

The flashing of the transparent red LED indicates communication with the Control Panel, and if it remains lit, it indicates an alarm status. The illumination of the green LED indicates activation of one or both inputs.



This device has an output for connection to a remote action indicator, which is activated when in alarm status. This element is electrical fed through the loop connection.

The MSTAY is conformant with EN 54-18 with the conformity mark awarded by AENOR. Connection will be made according to figure 6.

**Note: To determine the number of MSTAY it can be installed, consult the devices limit per control panel table (Chapter 1.5).**

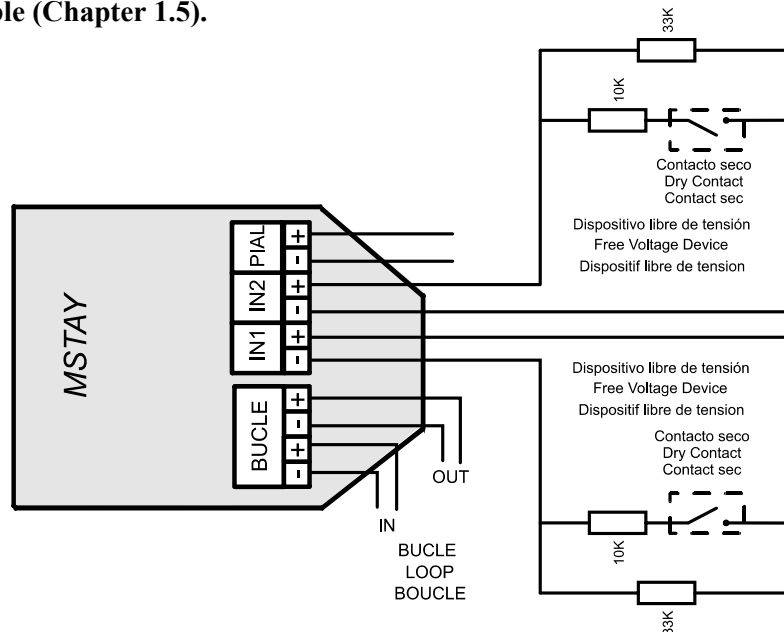

**IN1:** Gives an alarm signal to the control panel  
**IN2:** Gives a fault signal to the control panel

**Figure 6.** Connection schematic MSTAY

### 1.5.3.5- Loop isolator (KABY)

Microprocesed analogue element installed as another element inside the loop (It is not addressable - There is not need to configure this element).

This is a protection element that is connected into the detection loop, with the aim of isolating stretches with crossed line failures, and allowing therefore the rest of the loop to operate normally.

It is supplied installed inside of a high base. This assembly allows having it in the same place as the detector, making easy the connection of the loop wiring.

The base has two stickers in the outer side with the word “KABY” to allow easy recognition.

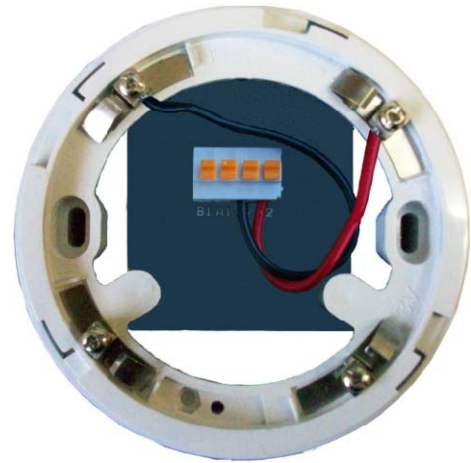

The element is feed from the loop connection.

The **KABY** is conformant with EN 54-17 with the conformity mark awarded by AENOR.

Connection will be made according to figure 7.

**Note: To determine the number of KABY it can be installed, consult the devices limit per control panel table (Chapter 1.5).**

**IMPORTANT The polarity in the KABY as shown in figure 7 must be observed.**

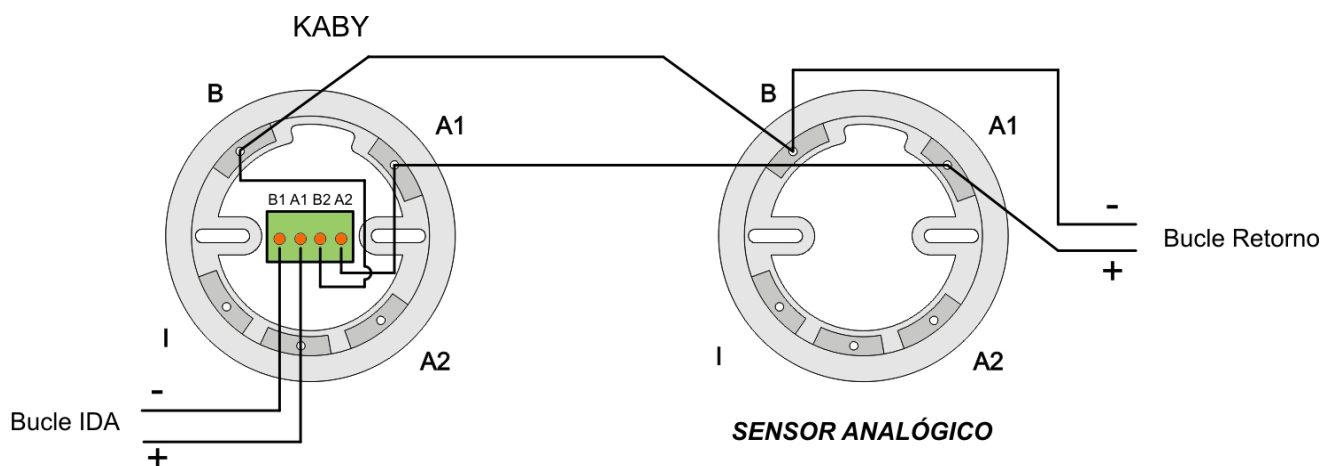

**Figure 7.** Connection schematic KABY

### 1.5.3.6- Addressable sounder (SIRAY / SIRAYL / SIRAY+BSLC)

Microprocessed addressable sounder (with short-circuit isolator) installed as another element inside the loop.

This sounder is manufactured in red plastic ABS.

It is a module with a single programming function respecting the timing and combination of sensors that activate it. This sounder is configured as a relay being able to act as a sounder.

The SIRAYL and SIRAY+BSLC variants additionally emits light signals, where, SIRAY+BSLC is EN 54-23 certified (visual alarm devices). The fact that these sirens emit light specifically does not affect the programming of control panel. For this reason, these devices are programmed in the control panel as it was SIRAY.

The standard configuration of the sound of the siren is shown in Figure 8A according to EN 54-3 (sounder). In the same figure the standard configuration of the light signal in the socket of the SIRAY+BSLC siren according to EN 54-23 (visual alarm device) is shown.

It is allowed to change the selection of the tone and light signal, but this operation affects the power consumption of the sounder, and therefore consumption elements equivalence of the device. Figure 8B is a table showing equivalence to tone selections (standard 95-1m dB and 105 dB maximum sound intensity-1m) and visual signal (W-2,4-2,3/7,5). Calculation can be made with the software of loop elements capacity calculation.

It is shown the microswitchs position for standard and maximum loudness at figure 8A, also including light signal for standard or maximum power emission.

Internal wiring and other microswitch positions should not be modified.



SIRAY



SIRAYL



SIRAY+BSLC

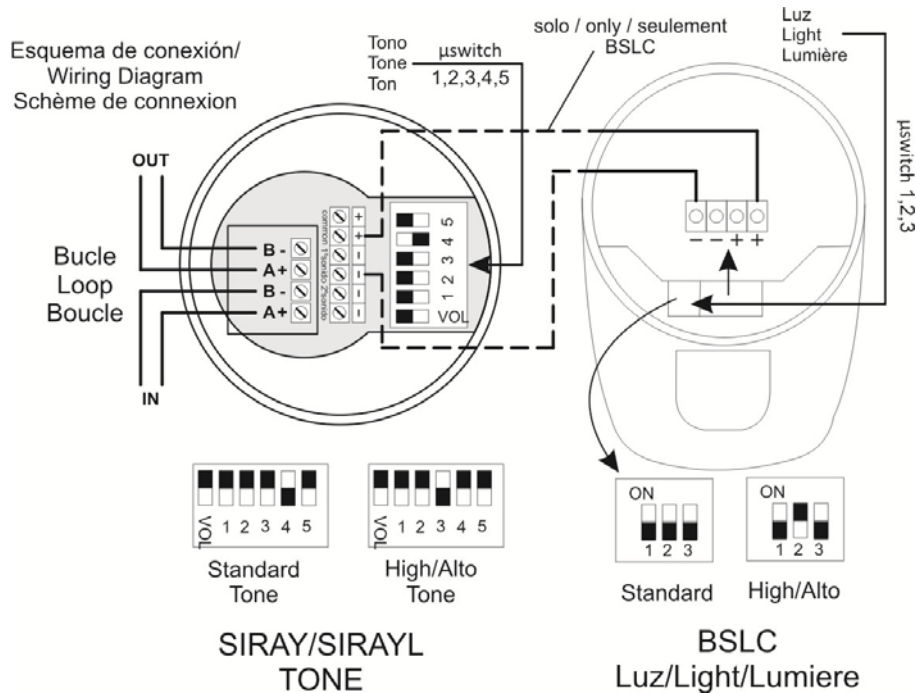

Figure 8A. SIRAY / SIRAYL / SIRAY+BSLC Schematic connection

Devices limits per Control Panel								
Reference	Description	LYON & ZAFIR control panel			C-Lyon Control Panel			
		Loop limit	Element equivalence		Cable section	Loop limit	Element equivalenc	Cable section
		Cable lenght	≤ 800 m	≤ 500 m	≤ 300 m	2x1,5 mm <sup>2</sup>	Cable lenght	≤ 800 m
SIRAY	Addressable sounder	32	8/16 <sup>A</sup>	6/12 <sup>A</sup>	4/8 <sup>A</sup>		32	4/8 <sup>A</sup>
SIRAYL	Addressable sounder with light	32	10/20 <sup>A</sup>	8/14 <sup>A</sup>	6/10 <sup>A</sup>		25	6/10 <sup>A</sup>
SIRAY+BSLC	Addressable sounder with EN 54-23 light	19	25/35/40 <sup>B</sup>	16/24/26 <sup>B</sup>	12/20/22 <sup>B</sup>		10	12/20/22 <sup>B</sup>

<sup>A</sup>) Values correspond with the standard/maximum sound intensity of the sounder.  
<sup>B</sup>) Value corresponds with the sound-light standard/ sound **or** light at maximum/ sound **and** light at maximum, sounder intensity  
 Note: The cable is considered with resistance of 32,9 Ω/Km\*mm<sup>2</sup> (Copper cable).

Figure 8B. SIRAY / SIRAYL /SIRAY+BSLC sounder limits by control panel

### 1.5.3.7- Master relay and technical signals module (MYOA)

Microprocessed analogue and addressable devices (with short-circuit isolator) installed as another element inside the loop.

This module has one relay output fed by external 30 V and one technical signal input to distinguish the open or closed state of a dry contact. The Module is protected by 0.9 A resettable fuse and the relay by 0,5 A.

It is required auxiliary 30 V for feeding the equipments connected to the relay output. The relay is configured with only one function (sounder, switched or crossed relay), but also in its timing and in the combination of sensors that activate it. The module monitors the presence of Voltage in the auxiliary supply line of 30V and in the output of the monitored relay. The voltage output of the relay is 30 V.

The technical signal input has a 10 K $\Omega$  resistor connected in serie with the dry contact. In quiescent condition, the contact has to be open, and in anomaly condition, the contact has to be closed. In the input (marked with IN2), the closed contact is detected as ALARM condition.

The MYOA supervises each external line (relay output and technical signal input) through a 33 K $\Omega$  each one, which allows indication of open or closed electrical connection status.

The flashing of the transparent red LED indicates communication with the Control Panel. The illuminated green LED indicates the actuation of the relay an alarm statu. Illumination of the green LED indicates activation of the relay or closed dry contact. This module is electrical fed through the loop connection.

The Realy and Technical signal Module is placed in a rectangular, heat-resistant ABS box.

The MYOA is conformant with EN 54-18 with the conformity mark awarded by AENOR.

The Realy and Technical signal Module is placed in a rectangular, heat-resistant ABS box.

**Note: To determine the number of MYOA it can be installed, consult the devices limit per control panel table (Chapter 1.5).**

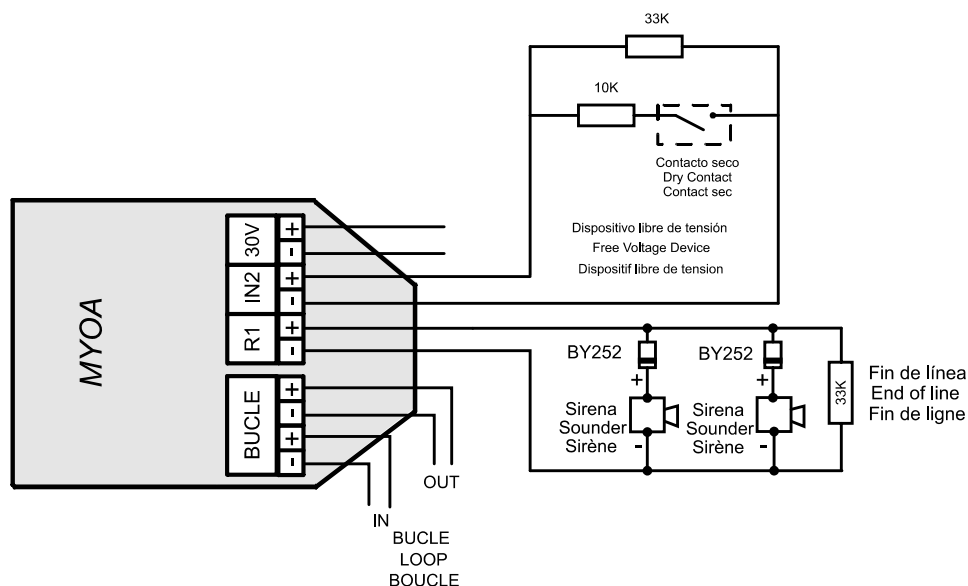

**Figure 10.** Connection schematic MYOA



## 1.5.4- Repeaters

### 1.5.4.1- Installation

The repeater must be fixed on a vertical wall face. The side slots must be left free for heat to escape. The dimensions and the pre-drilled holes for cable entry are shown in the following diagram.

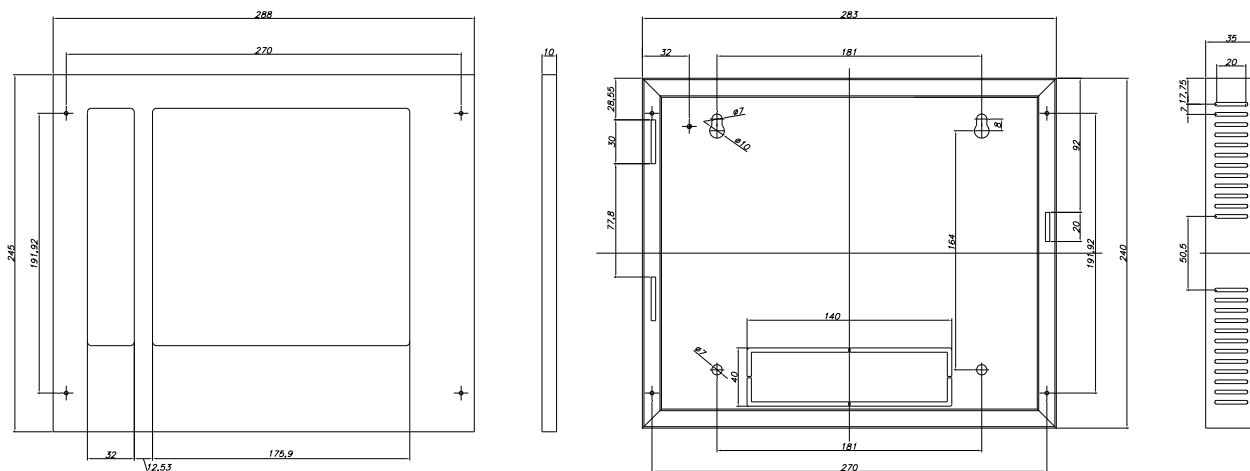

**Figure 10. C-Lyon repeater box**

The C-LYON control panel allows connecting up to 15 repeaters. For this, a 4-wire connection of 1.5 mm<sup>2</sup> wires (two for power supply and two for RS485 communication) must be used.

The two wires for the RS485 line must be connected from the connector indicated as REPETIDOR at the Control Panel, with each connector of the repeaters indicated as REPETIDOR on the label.

The two power supply wires must be connected from the 30 V output of the Control Panel power supply, with the connector indicated with 30 VDC in each repeater. Figure 11 shows this wiring diagram.

**It can be used the C-Lyon control panel's power supply 30V output for 1 repeater. In other cases (from 2 to 15 repeaters), it must be used the 30 V output of an auxiliary power supply (FAE).**

For repeaters connection, both the communication and 30V power supply cables must be **2 x 1.5 mm HALOGEN-FREE SCREENED BRAIDED CABLE**, with a maximum cable length of 1200 metres.

**DISCONNECT the 110~230V MAINS voltage and the BATTERIES before handling the inside of the control panel or the repeaters.**

### 1.5.4.2- Operation and Configuration

The repeaters display all the information about alarms, disconnections, relay actuations and faults. Once the repeaters have been connected, they must then be configured in the control panel by entering the number of each repeater to be configured. To do this, follow this sequence in the control panel: Menu (access code 27) → 4- System configuration (access code 9000) → 8- Communications → 1- Repeater network → 2- Configure repeaters.

After configuring the control panel, a number must then be assigned to each repeater. This must be the same as the one which was configured in the control panel. To do this, follow this sequence in the corresponding repeater: Menu (access code 27) → 1- System configuration (access code 9000) → 3- Repeater number.

When configuration has been completed, the general system reset must be performed from the control panel. To do this, follow this sequence: Menu (access code 27) → 8- General reset. The zone labels must then be sent according to this sequence in the control panel: Menu (access code 27) → 1- System configuration (access code 9000) → 3- Configure → 7- Send Zones to Repeaters.

Functions that can be carried out from the repeater:

- Reset alarms and faults.
- Activate or deactivate silence sounders.
- Activate or deactivate evacuation.
- Activate or deactivate manual mode.
- Activate or deactivate delays.
- Deactivate the buzzer.
- General reset.



### 1.5.4.3- Repeater menus

The following menus are accessible in the repeater:

- **SYSTEM CONFIGURATION**
  - **ADDITIONAL PASSWORDS:** From this menu, an additional password can be entered for access level 2 and another password for access level 3. Every time a new password is entered, the password entered previously will be deleted. The passwords which came pre-installed from the factory (access level 2: **27**; and in access level 3: **9000**) cannot be deleted.
  - **LANGUAGES MENU:** From this menu, the repeater's language can be selected. The repeater comes with Spanish, English and French pre-installed in the factory.
  - **REPEATER NUMBER:** From this menu, the repeater number to be used when communicating with the control panel can be selected. This number can never be used in more than one repeater.
- **GENERAL RESET:** From this option, the whole system can be reset. When the system is reset, all the events are deleted from the control panel and the repeaters, i.e. alarms, faults and relay actuations. The status of the elements and/or zones that are out of service is maintained.
- **SYSTEM TEST:** This option is used to test the repeater's indicators. In this test, all the leds should light up, the buzzer should sound, and the following screen should be displayed:

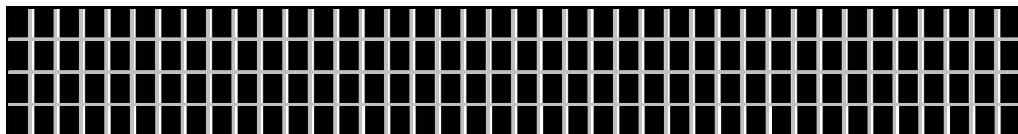

- **WELCOME MESSAGE:** From this option, the welcome message can be changed. The welcome message is the text that is displayed in the first line when the repeater is in standby. This message can have up to 20 characters. These are entered using the repeater's cursors or an external keyboard.

Central / Control Panel / Centrale  
C- LYON / ZAFIR

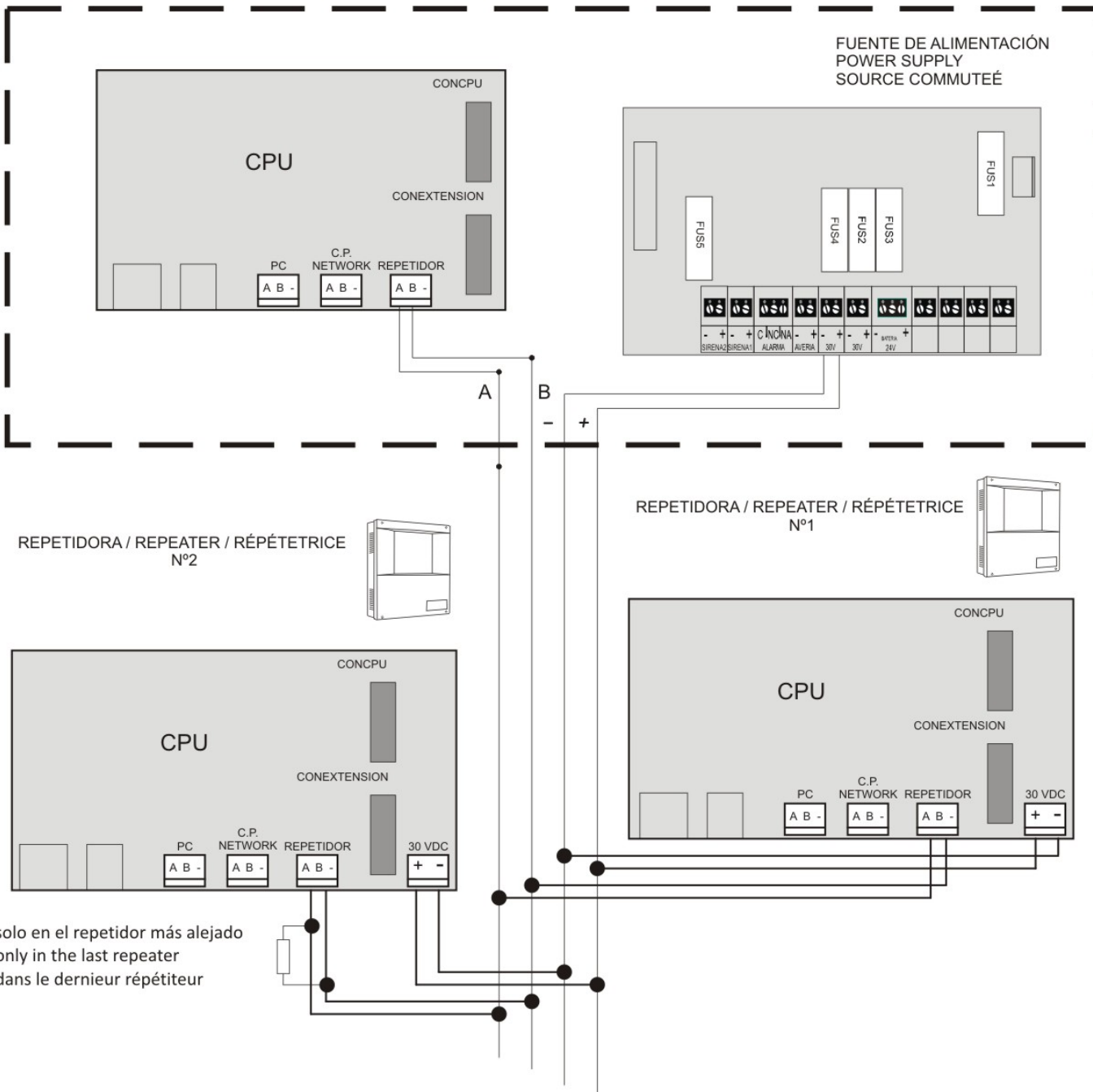
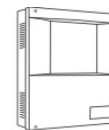

120 Ω solo en el repetidor más alejado  
120 Ω only in the last repeater  
120 Ω dans le dernier répéteur

**Figure 11.** Repeater connection

## 1.5.5- Control panel network

### 1.5.5.1- Installation

The control panel must be fixed on a vertical wall face. The side slots must be left free for heat to escape. The dimensions and the pre-drilled holes for cable entry are shown in the following diagram.

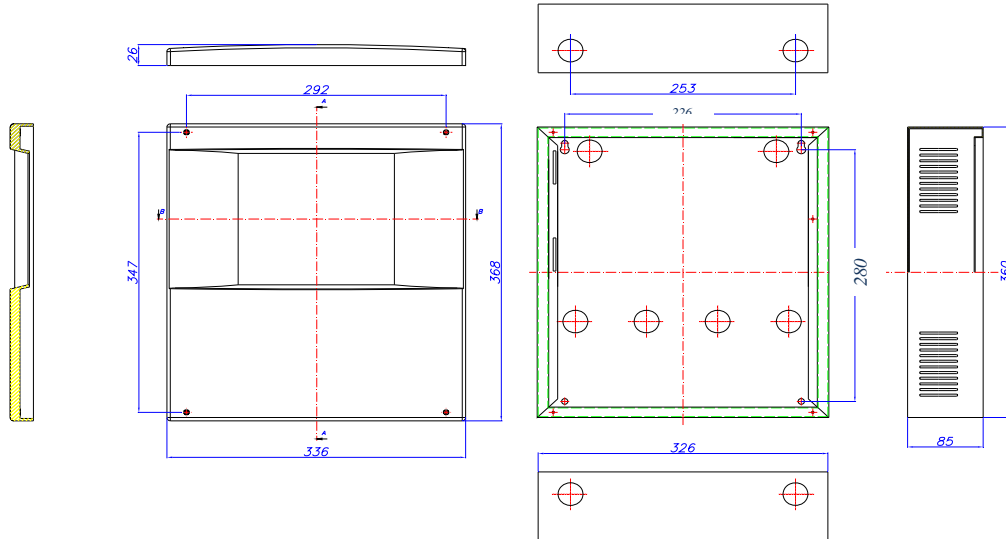

**Figure 12.** Compac Lyon box

**Cofem Digital Detection System** allows to connect up to 15 control panels in a network, by connecting 2 wires of 1,5 mm<sup>2</sup> (RS485 communication line). The two wires of the RS485 line will be connected from the CP NETWORK indication in the CPU card of each control panel.

This connection is shown in figure 13.

**Power is held in each control panel separately. Each control panel will be connected to the 110~230V mains and its corresponding set of batteries.**

The communication cables connection between control panels will be made with **cable 2 x 1,5 mm twisted shielded halogen free, up to a maximum cable length of 1200 meters.**

On completing the installation, a 120 Ohm resistor must be connected between the terminals A and B in the CP NETWORK connector both the first and the last control panel connected.

**DISCONNECT the 110~230V MAINS voltage and the BATTERIES before handling the inside of the control panel or the repeaters.**

### 1.5.5.2- Operation and configuration

Each control panel in the network displays all information from other control panel and interact with each other.

Once the power connection, proceed to the configuration in each of the control panels, entering the number of each (without repeat). For this we perform the following sequence in control panel menu (code 27): Menu (code 27) → 4- System configuration (code 9000) → 8- Communications → 3- Set control panel number.

After the configuration should perform a general reset at each control panel of the network. For this we perform the following sequence: Menu (code 27) → 8- General reset.

A control panel in the network can perform the same functions as any normal control panel. You can also perform the following functions on the rest of the control panels of the network:

- Reset alarms and faults in the network control panels.
- Reset all the network control panels.
- Enable or disable without delay mode in all network control panels.
- Enable or disable sirens stop in all network control panels.
- Enable or disable the evacuation in all network control panels.
- Enable or disable manual mode in all network control panels.
- Disable the buzzer in all network control panels.

### 1.5.5.3- Control panels network menu

In the control panels we can find the next specific control panels network menus:

- VISUALIZE CONTROL PANELS: Visualize the set control panels.
- RESET CONTROL PANEL NETWORK: Reset all the control panels in the network.
- SPECIAL FUNCTIONS:
  - WITHOUT DELAY: Enable or disable all the delays of all the relays associated with all network control panels.
  - OFF SIRENS: Enable or disable all the sirens stop associated with all network control panels.
  - EVACUATION: Enable or disable all the relays associated with all network control panels.
  - MANUAL MODE: Enable or disable manual mode in all network control panels.
- SETUP CONTROL PANEL NUMBER:
  - ENTER CONTROL PANEL NUMBER.
- CONTROL PANEL NUMBER:
  - VISUALIZE THE CONTROL PANEL NUMBER.

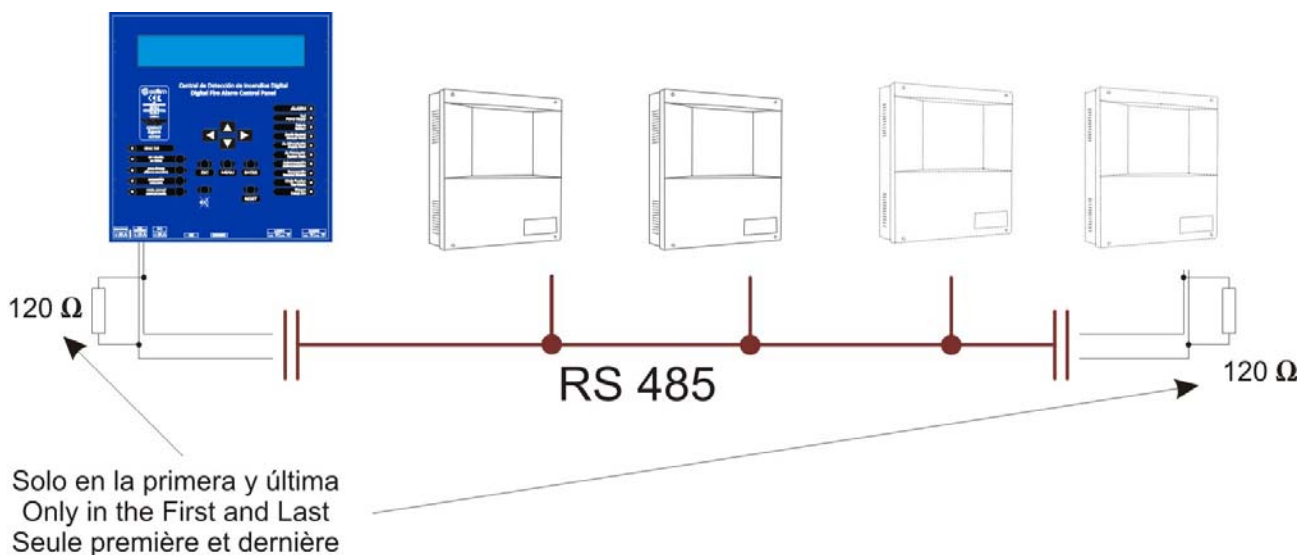

**NOTE:** Is due to connect a resistance of 120 ohms between the connectors

A and B of the connected strip of the first an last control panel in network

**Figure 13.** Control panels network connection

## 1.6- Accessories.

### 1.6.1- PC Keyboard

The control panel C-Lyon system allows a standard PC keyboard to be connected, with PS2 connector (minidin6), thereby enabling the programming and the labelling of zones, elements and relays.

### 1.6.2- PC based configuration software.

Software is available for the digital control panel C-Lyon (I-Link), that means of which the user can perform all the control panel programming in a simple and intuitive way. With this system it will be possible to maintain the configuration for future use.

The minimum configuration of the PC is:

- Windows 7,8,10
- 2 GB de RAM
- 1 GB de espacio libre en el Disco Duro
- DirectX9, resolución mínima 1024x768
- Puerto USB libre

## 2- Installation

### 2.1- Control panel installation.

The control panel must be assembled on a vertical face. The lateral grooves in the control panel must be left free for correct heat evacuation. The dimensions and pre-drilling for the cable input are in the following figure.

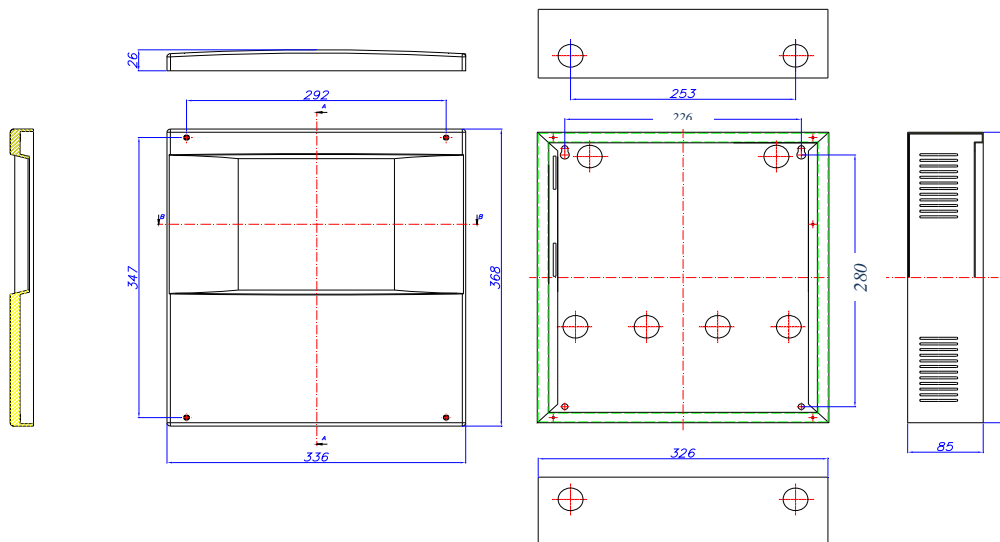

**Figure 14.** Control panel C-Lyon box

**In order to manoeuvre the Cover holder, care must be taken with the ground cable connecting one of its pin with a box pin or output circuit faston, and the connector of the CPU with the output circuit (see following figure/figure 24).**

**Any connection or movement of the control panel must be carried out with the panel disconnected, both from the power supply, and from the batteries.**

## 2.2- C-Lyon system connection

Connection of the Lyon digital system will be carried out with **2 x 1.5 mm BRAIDED CABLE SCREENED HALOGEN FREE**, both the loops as well as the sirens, KMAY connected elements and failure outputs and 30 volt supplies.

The loop must be connected using **HALOGEN-FREE SCREENED BRAIDED CABLE 2 x 1.5 mm** for lengths of up to **800 metres** and **HALOGEN-FREE SCREENED AND BRAIDED CABLE 2 x 2.5 mm** for lengths of up to **1500 metres**.

Connection of the loop elements will be carried out in accordance with the schematics indicated in figures 2, 3, 4, 5, 6, 7, 8, 9.

As the assembly of a loop sensor is performed (A30XTA, A30XHA and A30XHTCO), the cover on each sensor must be replaced until the installation is completely finished and clean.

A list must be made for each loop with the location, type and programming number of each element, this programming number goes from 1 to the 65533, see the example in the following table:

<b>Loop: 01</b>				
<b>POINT</b>	<b>Programming no.</b>	<b>Label</b>	<b>Type</b>	<b>Notes</b>
1	12757	ROOM 101	A30XHA	
2	12432	ROOM 102	A30XHA	
3	4767	BUTTON P1	PUCAY	
4	6982	CORRIDOR P1	MDA1Y	

**DISCONNECT the 110~230V Voltage circuit and BATTERIES before accessing the interior of the control panel.**

### 2.2.1- Electrical supply network.

Power supply is 110~230V  $\pm 10\%$  50 - 60 Hertz. Connection will be made by means of 3 strands with a minimum section of 1.5mm the connection of the earth cable to the terminal of the switched supply being obligatory. The maximum consumption for a control panel of up to 2 loops is 70 W. Connection will be made according to figure 13.

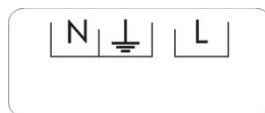

**Figure 15.** Switched Source

**DISCONNECT the 110~230V Voltage circuit and BATTERIES before accessing the interior of the control panel.**

**Do not cut power to the control panel during the boot process. Such action may cause malfunction of the unit.**

### 2.2.2- Loop driver

The standard control panel can have a maximum of 2 loop drivers, located inside.

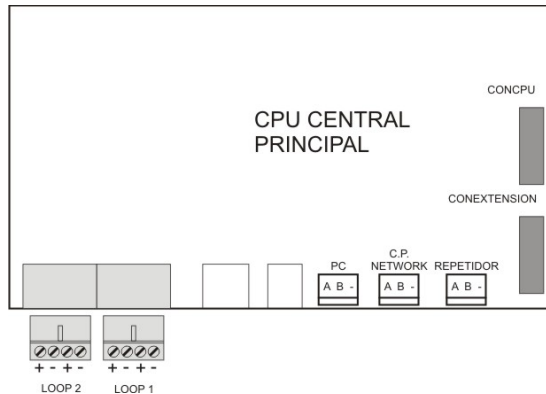

Figure 16. Loop driver

Each loop driver is numbered, to identify the corresponding loop. The numbering and the polarity come on the strip connector.

Connection of the loops of the C-Lyon digital system will be made with **2 x 1.5 mm BRAIDED SCREENED HALOGEN-FREE CABLE** for lengths of up to 800 metres and **2 x 2.5 mm BRAIDED SCREENED HALOGEN-FREE CABLE** for lengths of up to 1500 metres. Connection will be made according to figure 19.

**DISCONNECT the 110~230V Voltage circuit and BATTERIES before accessing the interior of the control panel.**

### 2.2.3- Power supply auxiliary outputs and charging of power source batteries.

- Power supply board:

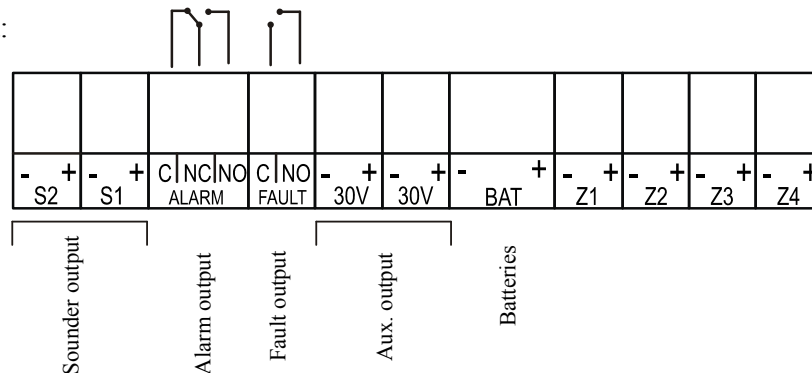

Batteries fuse	FUS3	4A
30V fuse	Auto-resettable fuse	0,75 A
S1 sounder fuse	Auto-resettable fuse	1,85 A
S2 sounder fuse	Auto-resettable fuse	0,75 A

Figure 17. Power supply auxiliary outputs

- SIRENA Sounder**

Output of the monitored siren and protected by means of a fuse, to which a delay can be applied by means of the configuration menu, see 3 chapter configuration. The installation of sirens will be performed according to the schematic of figure 19. It will be activated whenever an alarm occurs in the system and the programmed delay has passed. It is only deactivated when there is no alarm in the system.



- **ALARMA Alarm**

Unmonitored voltage-free output exit. It is activated whenever an alarm occurs in the system. It is only deactivated when there is no alarm in the system.

- **AVERIA Fault**

Non-monitored dry contact fault output, to which a delay can be applied by means of the configuration menu, see 3 chapter configuration. It will be activated whenever there is a fault in the system or not has power (the Common-Normally Open (NO) relay contact is shorted, indicating fault) and the programmed delay has passed. It is only deactivated when there is no fault in the system and the control panel is powered (the Common-Normally Open (NO) relay contact is electrically open).

- **30V output**

This is a 30V output that enables the supply of analogue modules or relays or other external devices. This output is monitored and protected by means of a fuse.

## 2.3- Components

### 2.3.1- Batteries

The supervised battery input/output allows the connection of batteries to the control panel. The batteries are charged through this connection as well as the monitoring of its status. The battery charge is compensated depending on the temperature of the batteries. This input/output is protected by a fuse and also against inversion of polarity. In addition to this fuse there is the battery charger fuse.

The capacity of the batteries that are incorporated into the control panel will depend on the number of loops and additional loads (e.g. relays modules), 7 Ah being the minimum recommended. Batteries with a capacity of 15 Ah or 24 Ah will have to be housed in a box external to the control panel, **ref C-55**.

Connection of the two 12V batteries in series is exactly as indicated in figure 18.

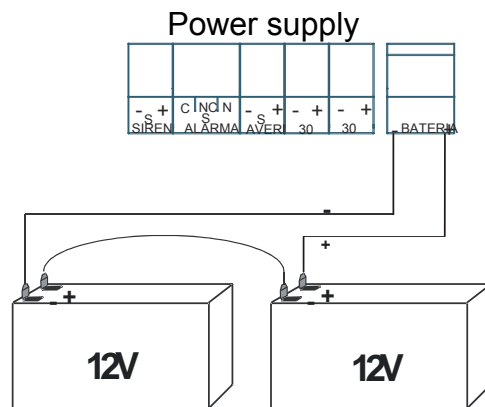

**Figure 18.** Battery connection schematic

### 2.3.2- Connection schematic of a typical loop.

Connection of the C-Lyon digital system will be made with **CABLE OF 2 x 1.5 mm TWISTED AND SCREENED HALOGEN FREE** not only loops but also sounder and fault outputs and elements connected to the KMAY and the 30V supplies.

The loop is to be connected using **2 x 1.5 mm TWISTED AND SCREENED HALOGEN FREE** for lengths of up to 800 metres and **2 x 2.5 mm TWISTED AND SCREENED HALOGEN FREE** for lengths of up to 1500 metres.

NOTE: For specific details of how each element is to be connected, please see the relevant chapter.

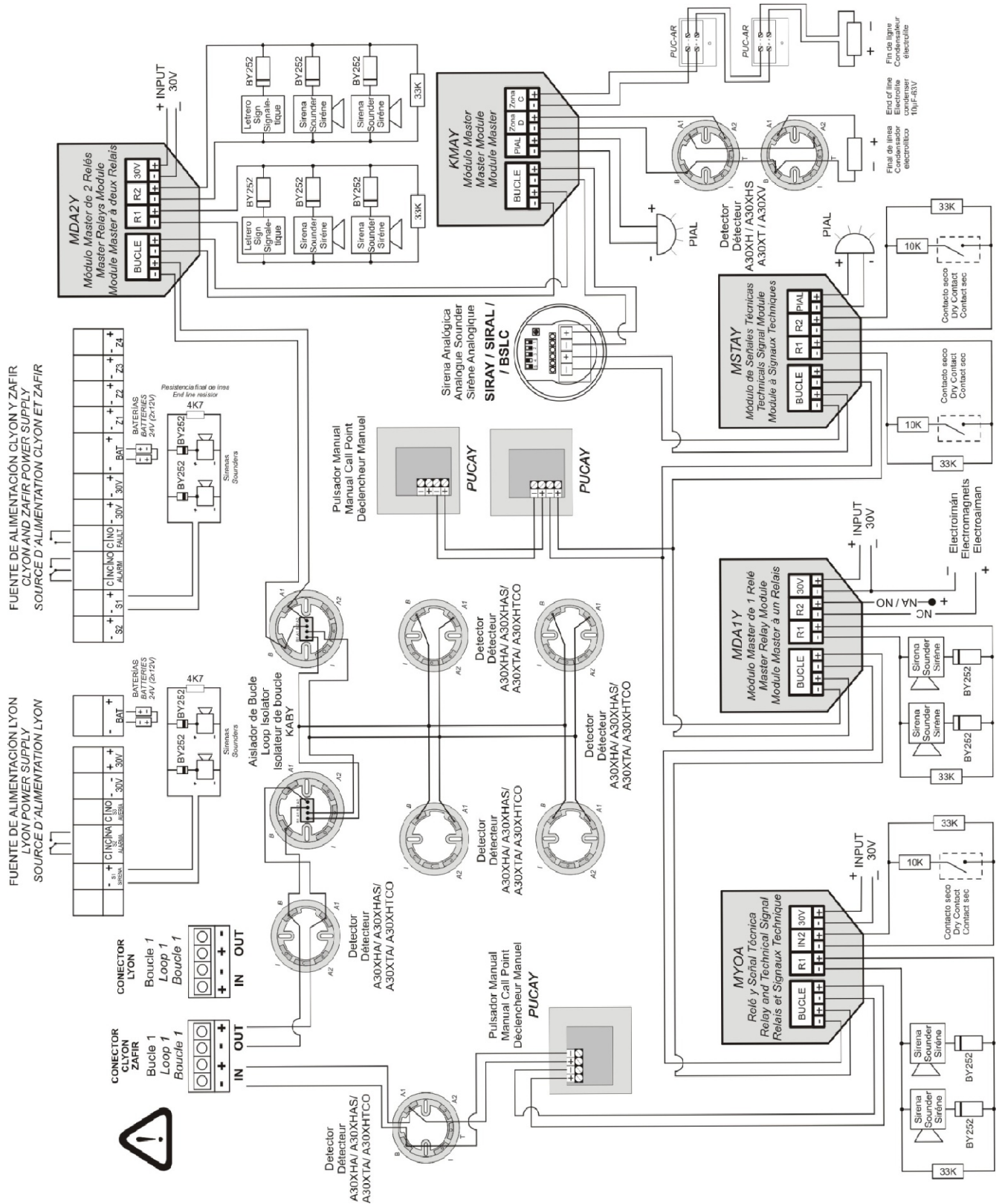

Figure 19. General Wiring Diagram

### 2.3.3- Sounder and controls with relays.

#### 2.3.3.1- Connection of the internal two tone 24V Sounder (SIR-24B / SIR-24BL)

Elements needed for its correct installation:

- 1 Resistance 33 K $\Omega$ , in the event of being connected to the general sounder the resistance is 4K7, included in the control panel and/or modules.
- 1 Diode BY252, two diodes are included with each control panel C-Lyon system.

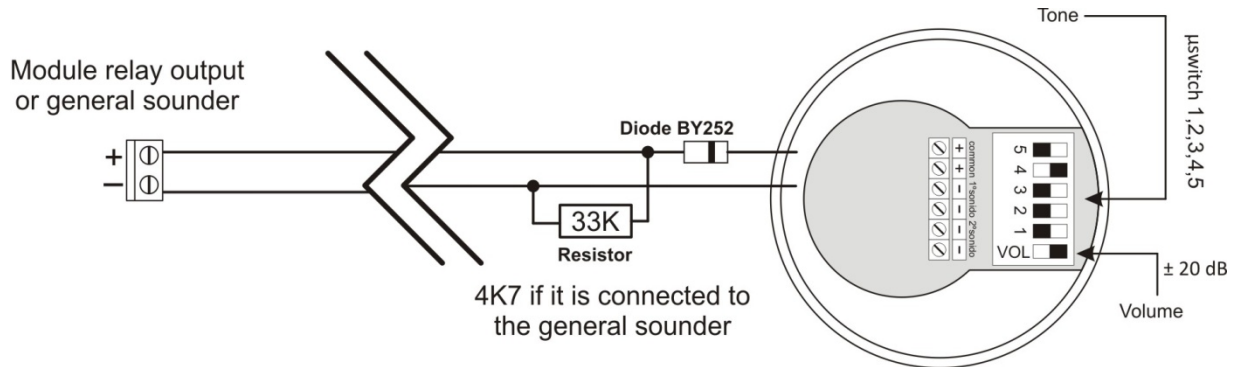

Figure 20. SIR-24B/BL connection schematic

**NOTE: An auxiliary 30 V supply is necessary for MYOA, MDA1Y and MDA2Y modules**

#### 2.3.3.2- Connection of the non-flashing internal 24V Sounder (SIR24P)

Elements needed for its correct installation:

- 1 Resistance of 33 K $\Omega$ ; in the event of the sounder being connected to the general sounder, the resistance should be 4K7, which is included in the control panel and/or the modules.
- 1 BY252 Diode; two diodes are included with each C-Lyon control panel.

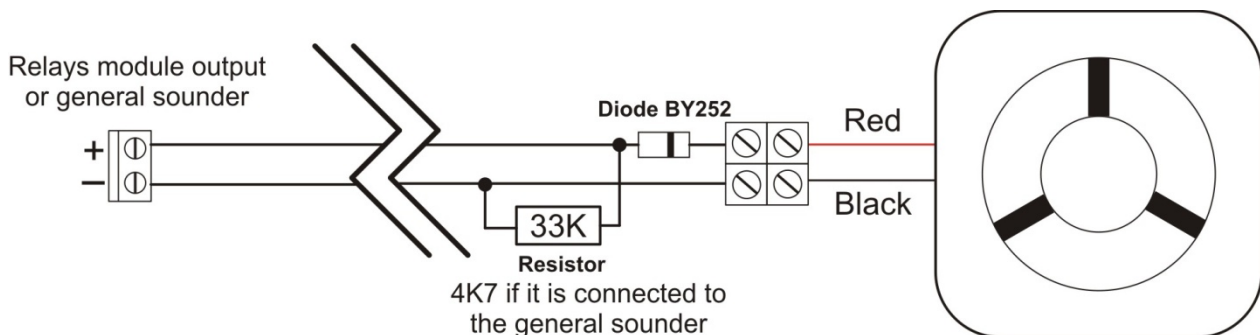

Figure 21. SIR24P Connection schematic

**NOTE: An auxiliary 30 V supply is necessary for MYOA, MDA1Y and MDA2Y modules**

### 2.3.3.3- Connection of the flashing internal 24V Sounder (SIR24F)

Elements needed for its correct installation:

- 1 Resistance of 33 K $\Omega$ ; in the event of the sounder being connected to the general sounder, the resistance should be 4K7, which is included in the control panel and/or the modules.
- 1 BY252 Diode; two diodes are included with each C-Lyon control panel.

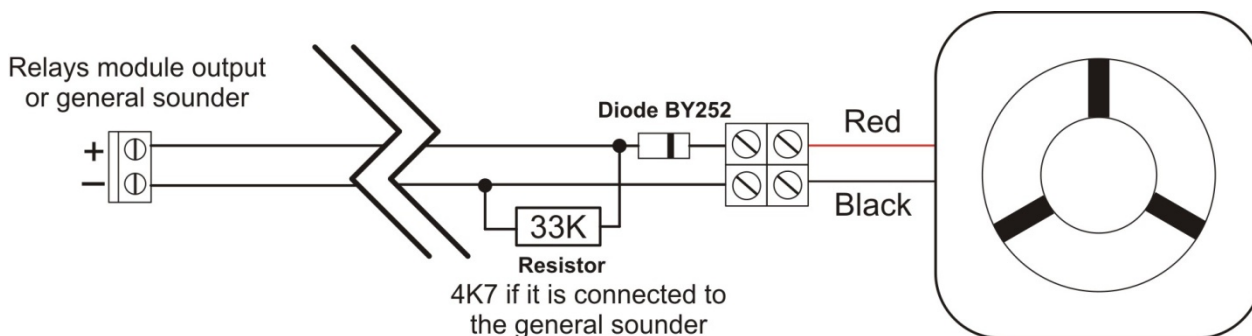

Figure 22. CAE24V Connection schematic

**NOTE: An auxiliary 30 V supply is necessary for MYOA, MDA1Y and MDA2Y modules**

### 2.3.3.4- Connecting the external 24V alarm box (CAE-PL)

Elements needed for its correct installation:

- 1 33 K $\Omega$  Resistance; in the event of the sounder being connected to the general sounder, the resistance should be 4K7, which is included in the control panel and/or the modules.
- 1 BY252 Diode; two diodes are included with each C-Lyon control panel.

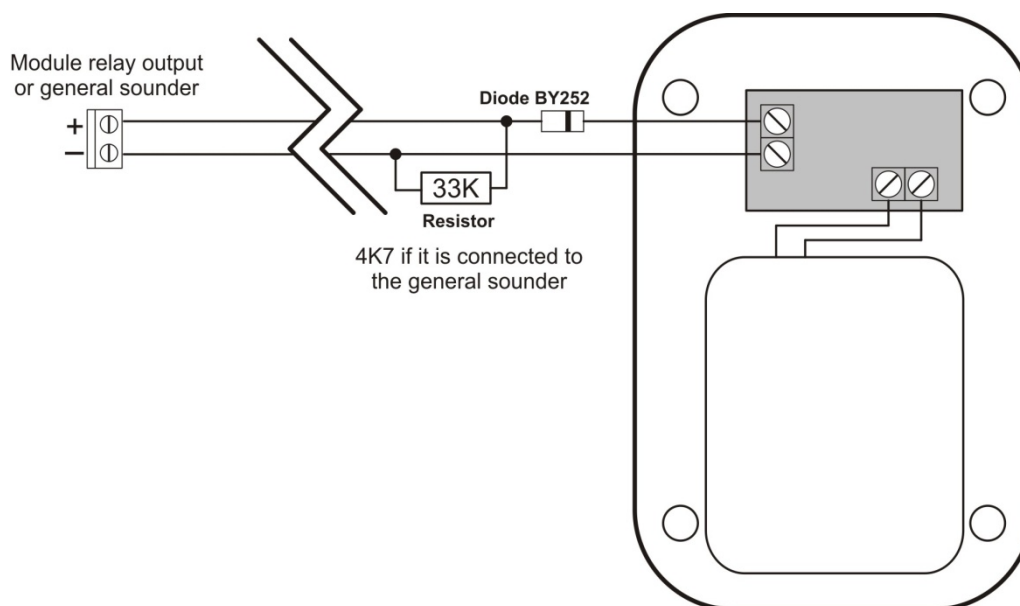

Figure 23. CAE24V Connection schematic

**NOTE: An auxiliary 30 V supply is necessary for MYOA, MDA1Y and MDA2Y modules**

## 2.4- Accessories.

### 2.4.1- PC keyboard

The standard keyboard, with PS2 connection, will be connected to the plate located in the door of the control panel as in the attached drawing.

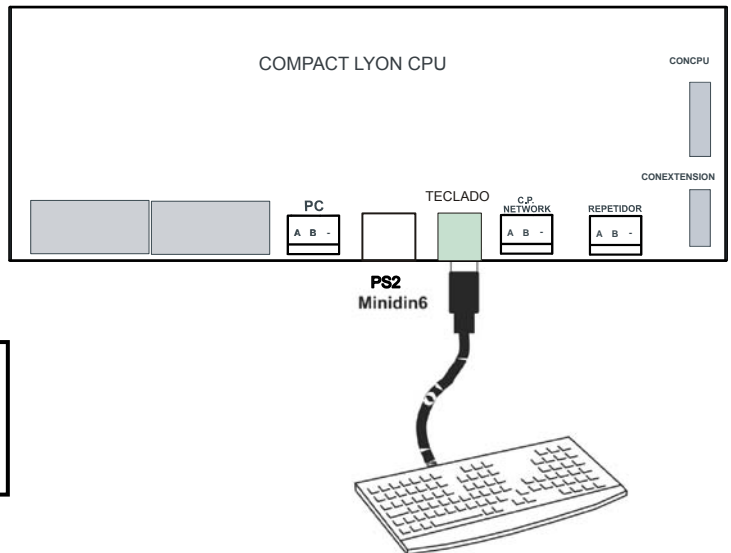

**DISCONNECT** the control panel and repeaters from the MAINS 110~230V and the BATTERIES before connecting the external keyboard.

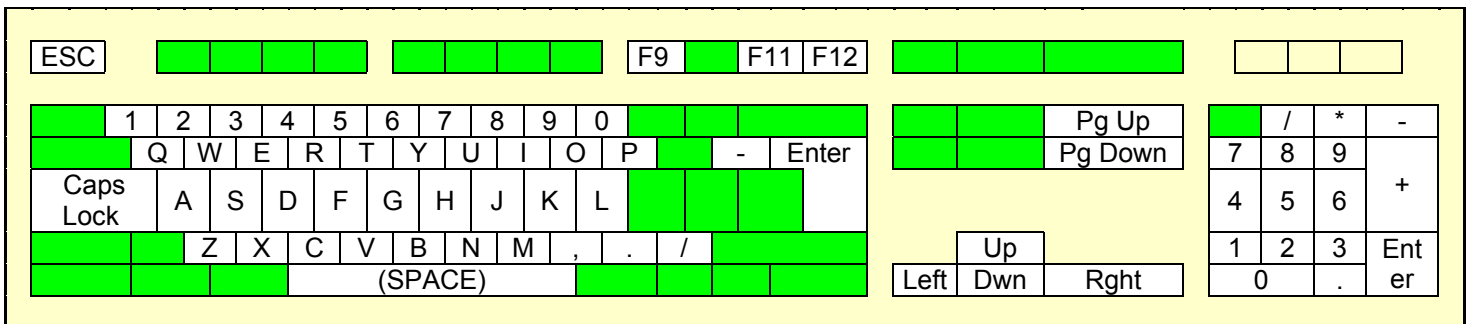

F9 – Silence buzzer

F11 – Menu

F12 – Reset

Pag+ – Go forwards three options in any menu and one loop in the monitoring screen

Pag- – Go backwards three options in any menu and one loop in the monitoring screen

+ Numeric keypad – Advance one relay in the logical relay configuration menu and one loop in the loop configuration menu

- Numeric keypad – Go back one relay in the logical relay configuration menu and one loop in the loop configuration menu

## 2.4.2.- Computer.

The **C-Lyon Digital Control Panel** system can use software (I-Link), with which the user can completely programme the control panel, easily and intuitively. By using this system, the configuration can be saved for future use.

Minimum PC Configuration:

- 1.8 GHz
- Windows 7,8,10
- 2 GB de RAM
- 1 GB de espacio libre en el Disco Duro
- DirectX9, resolución mínima 1024x768
- Puerto USB libre

As shown in the diagram the connection between the PC and the control panel must be made using a USB 2.0 PORT.

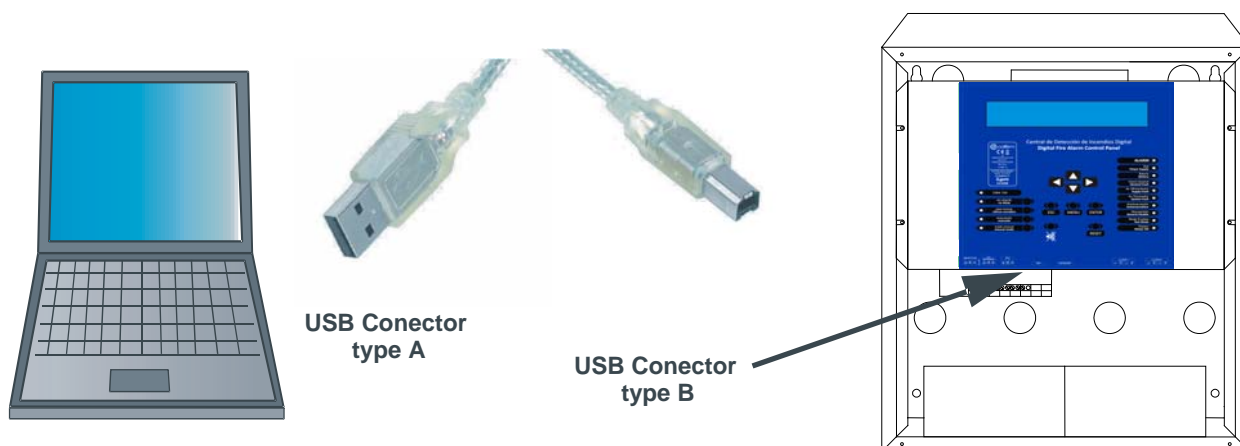

**The connection to the USB port must be made using a cable no more than 3 metres long.**

The use of the I-Link program and the configuration of the communication ports of the computer are described in the manual (Manual I-Link).

In case of installing the ON-LINE functionality of the I-Link, instead of using the USB connection, it must be used the RS485 one indicated as PC on the Control Panel label. This allows avoiding possible communication interferences and longer separation distances between Control Panel and PC. It is shown some examples of connection in the following figure.

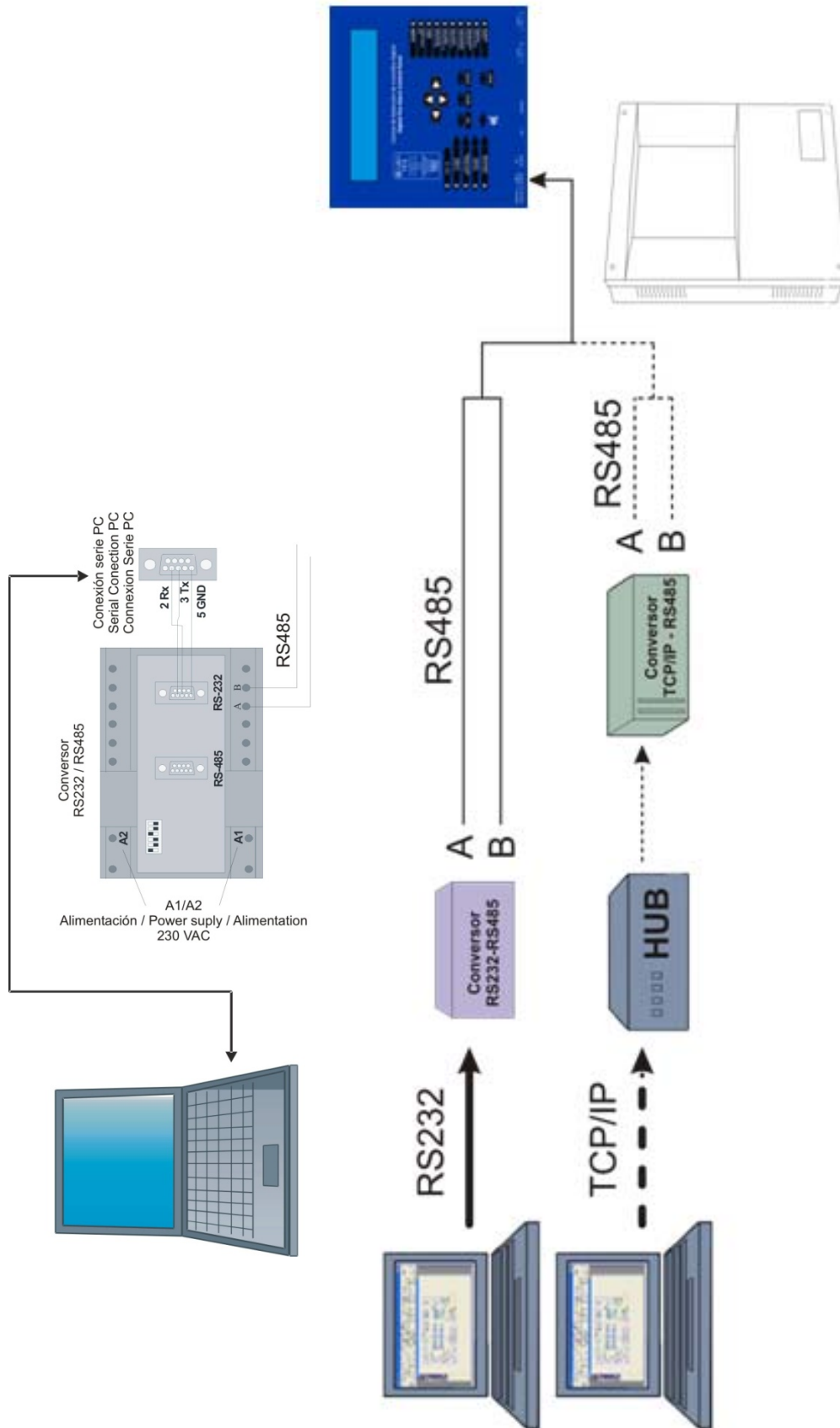

Example of PC (I-Link ONLINE) to ZAFIR connection for long distances  
(through a RS232/RS485 or TCP/IP convertor)



### 3- Operation and configuration.

#### 3.1- Description of the front panel.

##### 3.1.1- Keypad.



Disable the configured relay delays

Disable all relays that are configured as sirens.

Activate all relays programmed as sirens and switches.

Change to manual mode and disable all automatic relay activations.

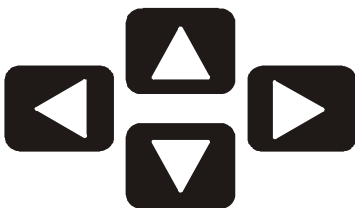

These cursors allow us to move through the menu that appears on the screen and to select characters in text mode.



**ESC** Key that enables the user to pass from one level to a higher level in the menu tree of the control panel and to cancel menu selections



**MENU** This key enables us to enter the control panel menu and to show the help text of the various menus.



**ENTER** This key enables us to confirm a selection.



**SILENCE BUZZER**



**RESET** Key that enables the user to reset events that have occurred in the system.

##### 3.1.2.- Light indicators.

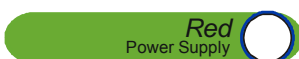

Green LED indicating that the system is working by means of the 110~230V network.



Green LED indicating that the system is working from the batteries. The POWER SUPPLY LED is off.



Amber LED indicating that the control panel is working in test mode or some zone is working mode.





## Control panel menu:

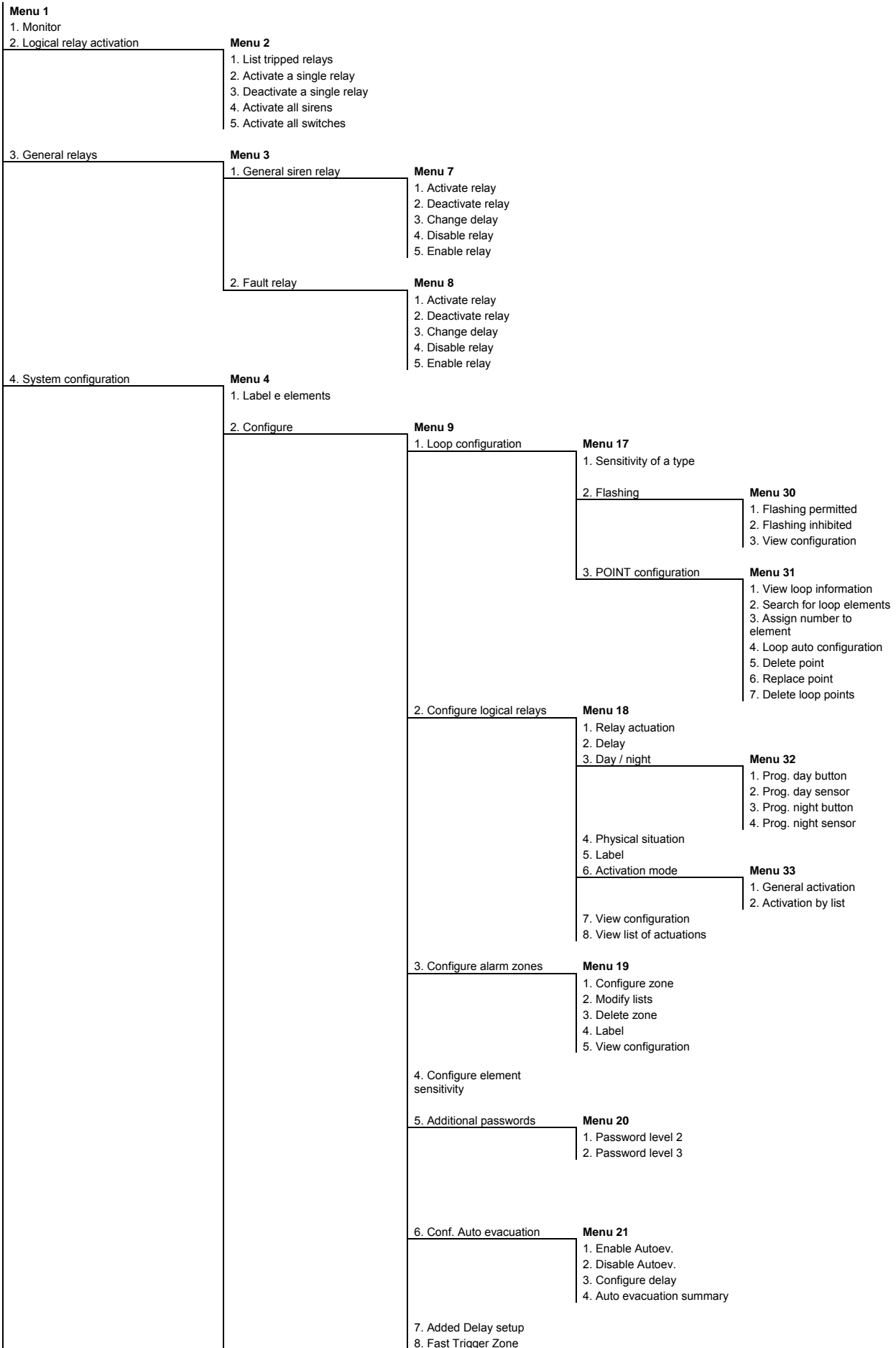

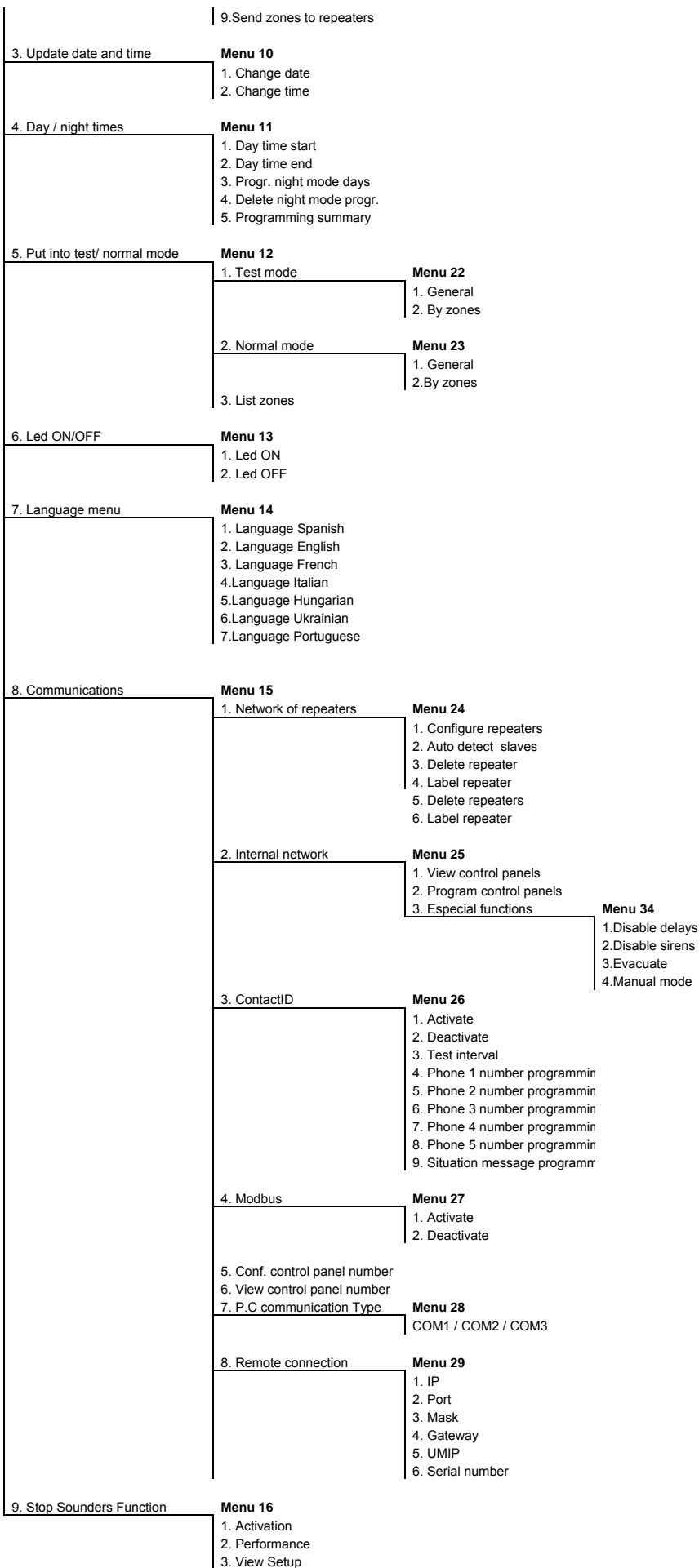

<p>5. Put element s/ zones into/ out of service</p>	<p><b>Menu 5</b></p> <ol style="list-style-type: none"> <li>1. Put point into service</li> <li>2. Set point out of service</li> <li>3. Put zone into service</li> <li>4. Set zone out of service</li> <li>5. List out of service zones</li> </ol>
<p>6. System test 7. Welcome message 8. General Reset 9. Review history</p>	<p><b>Menu 6</b></p> <ol style="list-style-type: none"> <li>1. Review complete history</li> <li>2. Review alarms</li> <li>3. Review faults</li> <li>4. Review disabled items</li> <li>5. Review relays</li> </ol>

### 3.2.1.- Level 1 access.

#### 3.2.1.1.- Activation of the control panel.

- If the control panel is starting up correctly we see:

```
CDID Zafir Vx
(C) Cofem, S.A.
Loading.....
```

V.x corresponds the version number of the control panel's software.

- The control panel is looking at the previous configuration data:

```
Recovering previous configuration
Zones: [ ]
Relays: [ ]
Updating System [ ]
```

- The control panel is performing an automatic element search:

```
Waiting Automatic Search .....
MODE 12 / 08 / 06
SEARCHING 10 : 29
```

- When the control panel reaches at this screen and it remains, this confirms to us that the control panel has been initialized correctly and that no alarms or faults of any type exist in the system. Only the green LED is illuminated (Power). It is also possible that other screens appear indicating anomalies of some type that are described in the following cases.

```
CDIC Zafir Cofem s.a.
MODE MODE 12 / 08 / 06
NIGHT AUTOMATIC 10 : 29
```

- **Anomalies during start-up:**

1. During the starting the possibility exists that memory I2C, where all the information keeps from the control panel, fails. In this case, we have two possibilities. One first that would allow us to reinitiate the configuration of the control panel being restored the values of factory (except labels of points and relays). Or one second, with that we could cancel the resumption of the

configuration. If after to have reinitiated the control panel it returns to appear the message of “Failure I2C” it is that this one does not work correctly.

```

Failure I2C
The configuration will restart
Press ENTER to continue
Press ESC to cancel
  
```

### 3.2.1.2. Incident and anomaly display.

Incidents and anomalies appear on the screen following this order of priority:

- Alarms
- Relays on
- Faults
- Disabled zones and points
- Supply faults

#### • Alarms

If an alarm takes place, the control panel will illuminate the red ALARM LED, sound the buzzer and show the following screen.

In order to be able to select from amongst the different alarms, we must move using the up and down cursors. The first line of the alarm corresponds to the selected alarm, whereas the second field refers to the last alarm received.

```

ALARMS                                     TYPE :
0 1 > LABEL                                CALL POINT
                                           0 1 / 0 1
  
```

If the right cursor is pressed we will be able to see the rest of the alarm information.

```

                                           Unit  Loop  Point
                                           |     |     |
ALARMS                                     C :  B :  Pt :
0 1 > Z : 0 0 1 LABEL                     0 1  0 1  0 0 6
                                           << 0 1 / 0 2
  
```

#### • Relays on

If the control panel actuates a relay, it will illuminate the amber RELAYS ON LED, sound the buzzer and show the following message:

```

TRIGGER                                     RELAY :
0 1 > LABEL                                ALARM RELAY
0 2 LABEL                                0 0 6
                                           >> 0 1 / 0 2
  
```

If the right cursor is pressed we will be able to see the rest of the activation information.

```

                                           Unit  Loop  Point
                                           |     |     |
TRIGGER                                     C :  B :  Pt :
0 1 >                                     - - - -
0 2                                       0 1  0 1  0 0 6
                                           >> 0 1 / 0 2
                                           |     |
                                           Selected trigger  Triggers
  
```



If the right cursor is pressed we will be able to see the rest of the fault information.

F A U L T S										C :	B :	P t :
0 1 > Z :	0 0 1									0 1	0 1	0 0 1
0 2 Z :	0 0 3									0 1	0 1	0 0 3
										> >	0 1 / 0 2	

- Within point faults the following types of fault exist:

	Type of fault	Description
All elements	POINT NO REPLY	Communication fault with point.
A30XHA	DIRTY SENSOR	The A30XHA sensor has a dirty optical camera.
A30XHA-S	DIRTY SENSOR	The A30XHA-S sensor has a dirty optical camera.
A30XHTCO	DIRTY SENSOR	The A30XHTCO sensor has a dirty optical camera.
MDA1Y, MDA2Y, MYOA	SC RELAY (N°)	Short circuit in logical relay.
	OC RELAY (N°)	Open circuit in logical relay.
	24V RELAY (N°)	Absence of 24V in the relay module.
	RELAY NOT ACTIV.	It has not been possible to activate the relay.
MSTAY, MYOA	SC INPUT	Input short circuit
	OC INPUT	Input open circuit
Master modules	S. L. MASTER	Short circuit in the zone of the master module.
	O. L. MASTER	Open master circuit (the circuit is not closed with a line terminating condenser).

- General sounders faults

If the control panel detects a failure in the power supply to any of the two general sounder, it will illuminate the amber GENERAL FAILURE LED, sound the buzzer and show the following message.

F A U L T S										T Y P E :		
0 1 > S U P P L Y	C O N T R O L									A C R E L A Y :	0 1	
0 2 S U P P L Y	C O N T R O L									O C R E L A Y :	0 2	
											0 1 / 0 2	

Relay number

The relay number indicates to us, in this example, which of the two sounders is faulty (R1 shown as 01 and R3 as 03). Within general sounder faults, we have these types of fault:

Type of fault	Description
SC RELAY (N°)	Short circuit in the general sounder relay.
OC RELAY (N°)	Open circuit in the general sounder relay.

### 3.2.1.3- Moving through incidents.

Once the control panel has displayed any of the incidents described above, the user will be able to move among them using the “up and down” cursors and with the right cursor we will be able to see more information about the selected incident.

Incidents of the same type are always displayed on the screen in chronological order. On the screen, we have a maximum of two incidents. The incident that appears in the lower part of the screen is the last incident that has taken place and the incident in the upper part is the selected one, which we can change with the up and down cursors.

In order to change the type of incident on the screen we must press the ENTER key.







### 3.2.2.10- Welcome message

Option 7 of the main menu. From this option it is possible to change the welcome message. The welcome message is the text that appears on the first line when the control panel is in standby. This message can have a maximum of 40 characters, which we will enter by means of the control panel cursors or an external keyboard.

### 3.2.2.11- General reset.

Option 8 of the main menu. From this option it is possible to reinitialise the whole system. When resetting the system all the control panel events are deleted, that is to say, alarms, faults and actuations. It maintains the state of the out of service elements and/or zones.

### 3.2.2.12- Review history

Option 9 of the main menu menu. In this menu we have 5 submenus: REVIEW COMPLETE HISTORY, REVIEW ALARMS, REVIEW FAULTS, REVIEW DISABLED ITEMS and REVIEW RELAYS.

By means of the up and down cursors we will move through the various stored events. The events are stored in chronological order from the most recent to the oldest, storing a maximum of 4095 events. Once 4095 events are stored, the control panel will automatically delete the oldest in order to store a new event.

- **Review complete history:** This enables each of the incidents detected by the control panel to be reviewed, understanding by incident: disabled alarms, faults, zones and elements and actuations of relays.
- **Review alarms:** This submenu is the same as the one to review the complete history except that is exclusively for alarms.

Type of event				Type of alarm			
NUM : 003		ALARM		CALL POINT			
LOOP : 01		POINT : 005		N . Prog : 00001			
ZONA : 01		C . PANEL : 01		01 / 01 / 07	12 : 01		
LABEL :		B : 1 P : 5 NS : 1					

- **Review faults:** This submenu is the same as the one to review the complete history except that is exclusively for faults.

Type of event				Type of alarm			
NUM : 003		FAULT :		CC RELAY			
LOOP : 03		POINT : 003		N . Prog : 00003			
ZONE : 01		C . PANEL : 01		01 / 01 / 07	12 : 01		
LABEL :		B : 3 P : 3 NS : 3					

- **Review disabled items:** This submenu is the same as the one to review the complete history except that is exclusively for disabled items.

Type of event				Type of item disabled			
NUM : 001		DISABLED		DIS . ELEMENT			
LOOP : : 01		POINT : 001		N . Prog : 00120			
ZONE : 01		C . PANEL : 01		01 / 01 / 07	12 : 01		
LABEL :	:	B : 1 P : 1 NS : 120					

- **Review relays:** This submenu is the same as the one to review the complete history except that is exclusively for relays.

Type of event				Type of actuation			
NUM :	0 0 4	ACTUATION	0 1	SELF .	ACTIV		
LOOP :	0 3	POINT :	0 0 2	N . P r o g :	0 0 0 2		
ZONE :	- -	C . PANEL :	0 1	0 1 / 0 1 / 0 7	1 2 : 0 1		
LABEL :		B : 3	P : 2	NS : 2			

### 3.2.3- Level 3 access.

#### 3.2.3.1- Access code.

When entering the SYSTEM CONFIGURATION menu, we gain access to level 3 by means of a code (9000). From this menu we can configure the whole system.

#### 3.2.3.2- Label elements.

Option 1 of the SYSTEM CONFIGURATION menu. We will have to introduce the loop and element number to label. This is an option that allows us to label each element of the system, that is to say, to give each point a description that gives us the information necessary to physically locate it in the installation. The label can have a maximum of 20 characters. This is the screen that appears during the labelling process:

ENTER TEXT :																				
OFFICE																				
MENU - > COPY																				
RESET - > PASTE																				
ENTER - > ACCEPT																				

In order to introduce the label we can use the control panel cursors or an external keyboard.

#### 3.2.3.3- Configure.

Option 2 of the SYSTEM CONFIGURATION menu.

##### 3.2.3.3.1- Loop configuration.

Option 1 of the CONFIGURE menu. In this menu we have the possibility of configuring all the parameters related to the element of a loop such as: to assign the element numbers, to detect the elements, to configure sensitivity, etc.

Within the LOOP CONFIGURATION menu we have three important submenus that are:

- SENSITIVITY OF A TYPE: This submenu allows us to vary the sensitivity of all the sensors configured in the loop according to the type. Sensitivity has three levels HIGH, AVERAGE and LOW (all the sensors come with average sensitivity).
- FLASHING: This submenu allows us to enable/disable the blinking of all the elements configured in the loop.
- POINT CONFIGURATION: In this submenu we will be able to detect the elements that are connected to the loop and to assign a point number to them. Within this submenu we have seven submenus:
  - VIEW LOOP INFORMATION: In this submenu we can see the number of elements that are in the loop classified by type.

LOOP :			0 1	A 3 0 X H A / S :	0 0 4	S I R A Y :	0 0 0
P O I N T S :	0 0 5	A 3 0 X T A		:	0 0 0	M D A x Y :	0 0 0
		A 3 0 X H T C O :	0 0 0			M S T A Y :	0 0 0
M Y O A		:	0 0 0	P U C A Y		:	0 0 1
						K M A Y :	0 0 0

- **SEARCH FOR LOOP POINTS:** It detects elements in the installation and it shows a list the same as the one above.
- **ASSIGN NUMBER TO POINT:** To save the programming number of each point in the control panel. The programming number is the identification number that each elements has (from 1 to 65533 **and the same number may never be repeated in a loop**). The control panel must know this programming number to identify the elements.
- **LOOP AUTOMATIC CONFIGURATION:** It looks for the points of the loop and assigns the programming number to each point following the order of the programming numbers beginning by the smallest.
- **DELETE POINT:** To delete a point that is no longer connected to the loop and is still configured, delete the programming number and the label of the element.
- **REPLACE POINT:** Replace one point in the loop by another. This is the appropriate option to replace an element since it saves the label. Take into account that it is necessary to first physically replace the element with the control panel disconnected, then start up the control panel and lastly run this menu option.
- **DELETE LOOP POINTS:** To eliminate all the points configured in a loop both programming numbers and labels.

### 3.2.3.3.2- Configure logical relays.

Option 2 of the CONFIGURE menu. In this menu we have the option of configuring all the parameters referred to logical relays connected to the loop, that is to say, the type of actuation, delay, etc.

Within the CONFIGURE LOGICAL RELAYS menu we have eight submenus:

- **RELAY ACTUATION:** The relays can be configured as Sounders, Switches and relay.
  - **SOUNDERS:** these are activated automatically if they have been so configured and this is affected by the silence sounders button.
  - **MANOEUVRES:** these are activated automatically if they have been so configured and are not affected by the silence sounders button.
  - **Crossed Relay L:** this is activated automatically when there is 2 devices in alarm inside its activation List. It is not affected by the silence sounders button neither evacuation button.
  - **Crossed Relay SL:** this is activated automatically when there is 2 devices in alarm inside one of its activation Sub-List. It is not affected by the silence sounders button neither evacuation button.  
NOTE: There is a manual call point version PUCAYEXT. This device is computed by control panel as the activation of two devices. In this way, it allows triggering the crossed Relay L and Crossed Relay SL only activating this device.
  - **RELAY:** this is activated automatically and neither the evacuation nor the silence sounders keys affect it.
- **DELAY:** The time period within which the necessary alarms are generated in order for a logical relay to be activated and the actuation of the same. A delay of between 0 and 9 minutes 59 seconds is possible.
- **DAY/ NIGHT:** In this submenu we can configure the type of activation of a logical relay (active with or without delay, inactive) for a daytime and night schedule. We will be able to activate the day mode independently for every day of the week.
- **PHYSICAL SITUATION:** Loop and point number where the logical relay is.
- **LABEL:** To introduce a description of the relay for its identification in the installation.
- **ACTIVATION MODE:** Within this menu we find two options: General Activation and Activation by List.
  - **GENERAL ACTIVATION:** This option causes the relay to activate when an alarm occurs in any element of the control panel.
  - **ACTIVATION BY LIST:** We can configure the activation lists of the relay selecting the points that we want to activate the relay. When any one of the point defined in the list goes into alarm status, the relay activates. The control panel enables up to 8 different activation lists to be configured for each relay and they are configured by introducing a first and last point (the points that are configured in the list are the all elements consecutively from the first to the last entered point) in the same loop, except for the crossed relay function which does not allow for activation lists.
- **VIEW CONFIGURATION:** View the configuration of the relay and all its parameters.



### 3.2.3.3.7- Added Delay Setup

This is option 7 of the CONFIGURE menu. This option is activated when it is introduced a time between 1" to 9 min 59". When the first signal alarm is received, control panel activates corresponding programmed delays. If operator press "Silence Buzzer" before programmed delay time is finished, all the relays (including the sounder relay output in control panel) are additionally delayed with the value "Additional delay". In this way, operator is allow to investigate alarm. If in any moment of the delays there is a second signal alarm, all relays are activated immediately.

### 3.2.3.3.8- Fast Trigger Zone

This is option 8 of the CONFIGURE menu. The alarm signal input of any element defined in the zone introduced in this option makes immediately activation of all control panel relays.

### 3.2.3.3.9- Send Zones to Repeaters

This is option 9 of the CONFIGURE menu. This option allows sending the configured zones to the repeaters, of not realising it, the repeaters will only indicate the label of the point.

### 3.2.3.4- Update date and time.

This is option 3 of the SYSTEM CONFIGURATION menu. Within this menu we have two options, CHANGE DATE and CHANGE TIME. With the cursors we will be able to update the fields for both options.

### 3.2.3.5- Day/ Night times.

This is option 4 of the SYSTEM CONFIGURATION menu. Within this menu we have 5 submenus: DAY TIME START, DAY TIME END, PROG. NIGHT MODE DAYS, DELETE NIGHT MODE PROG. and PROGRAMMING SUMMARY.

The day/night mode serves to configure the activations of relays since they can have a different operation for day and night. The day mode can be activated or deactivated independently for the different days of the week.

- DAY TIME START: The control panel will request the start time for the day mode.
- DAY TIME END: The control panel will request the end time for the day mode.
- PROG. NIGHT MODE DAYS: This option allows us to configure the control panel night mode for the whole 24 hours of a day.
- DELETE NIGHT MODE PROG.: This option deletes the configuration described in the previous paragraph.
- PROGRAMMING SUMMARY: This option shows us the configuration of the night mode day for the control panel.

### 3.2.3.6- Put into test/ normal mode.

This is option 5 of the SYSTEM CONFIGURATION menu. Within this menu we have 3 submenus: TEST MODE, NORMAL MODE and LIST ZONES.

Test mode is the operating mode that allows us to activate the alarm of any control panel element without any of the configured relays activating. In addition all the alarms will reset automatically after 15 seconds. This mode is appropriate for performing tests and system maintenance.

- TEST MODE: Within this menu we have two options: we will be able to activate test mode generally or by alarm zone.
- NORMAL MODE: Within this menu we have two options: we will be able to activate normal mode generally or by alarm zone.
- LIST ZONES: This option shows us the operating mode of the control panel and the alarm zones.

### 3.2.3.7- Led ON / OFF.

This is option 6 of the SYSTEM CONFIGURATION menu. This menu allows activation or deactivation (If it is already activated) the led of one element of the loop. This functionality is activated if the element is inside a zone in test mode.

### 3.2.3.8- Language menu.

This is option 7 of the SYSTEM CONFIGURATION menu. From this menu the language of the control panel is selected. The control panel will be provided with seven languages as standard: Spanish, English ,French, Italian, Hungarian, Ukrainian and Portuguese.

### 3.2.3.9.- Communications.

This is option 8 of the SYSTEM CONFIGURATION menu. Within this menu we have two submenus:

- NETWORK OF REPEATERS:
  - SEE REPEATERS CONFIGURED: display the configured repeaters on the control panel.
  - CONFIGURE REPEATERS: Give the address of the repeaters with which it is desired to communicate.
  - AUTO-DETECT SLAVES: In this menu the connected repeaters are detected and the control panel will automatically communicate with these repeaters.
  - DELETE REPEATER: From this option the selected repeater is deleted.
  - DELETE REPEATERS: From this option, all the repeaters configured in the control panel are deleted.
  - LABEL REPEATER: In this menu we give a label to the repeater with a maximum of 20 characters.
- INTERNAL NETWORK:
  - SEE CONTROL PANELS: Visualize the configured control panels.
  - RESET CONTROL PANEL NETWORK: Reset all the control panels connected to a network.
  - SPECIAL FUNCTIONS:
    - NO DELAY: Activate or deactivate all the delays of all the relays associated to all the control panels of the network.
    - STOP SIRENS: Activate or deactivate the sirens stop of all the sirens associated to all the control panels of the network.
    - EVACUATION: Activate or deactivate all the relays associated to all the control panels of the network.
    - MANUAL MODE: Activate or deactivate the manual mode in all the control panels of the network.
- CONTACTID
  - ACTIVATE
  - DEACTIVATE
  - TEST INTERVAL  
Checking time of the communication with the receiving center.
  - PHONE 1 NUMBER PROGRAMING
  - PHONE 2 NUMBER PROGRAMING
  - PHONE 3 NUMBER PROGRAMING
  - PHONE 4 NUMBER PROGRAMING
  - PHONE 5 NUMBER PROGRAMING
  - SITUATION MESSAGE PROGRAMING  
Message sent to the phones configured in the previous options
- CONFIGURE CONTROL PANEL NUMBER:
  - SET CONTROL PANEL NUMBER.
- CONTROL PANEL NUMBER:
  - VISUALIZE THE CONTROL PANEL NUMBER.
- TYPE OF PC COMMUNICATION:



- The communication ports of the control panel are configurable with the different available functionalities. The control panel has 3 RS485 communications ports identified as CONPC (COM1), CONRED (COM2), CONREP (COM3) and a USB port identified as USB (USB1). In this menu you can select the port you want to use with the following features:
- NeTW: Connection port for connecting control panels in network.
- RePT: Connection port for connecting repeater.
- iLNK: Connection port for control panel software configuration I-Link or I-Link ONLINE.
- C\_ID: Connection port for ContactID.
- MoDB: Connection port for MODBUS.
- ReMT: Connection port for REMOTE card.

C o m m u n i c a t i o n   m o d e											
N e T W :			C O M 2	R e P T :			C O M 3	i L N K :			U S B 1
C _ I D :			-				-				R e M T :
			-				-				C O M 1
E N T E R :			S A V E ,				O P T I O N S :				U P - D O W N ,
											E S C : O U T

- REMOTE CONECTION:

It allows configuring the following communication parameters of the REMOTE card in the ethernet network.

- IP: Defines the IP address of the REMOTE card in the internal network. By default 192.168.0.254.
- PORT: Defines the port of the REMOTE card. The server / router must be configured to allow communication between the REMOTE card and the external network. By default the value is 80.
- MASK: Mask of the server / router that differentiates the IP addresses of the internal and external network. Based on the IP address of the server / router, the "0" values identify the internal addresses. By default, the value of the mask is 255.255.255.0.
- GATEWAY: IP address of the server / router. By default the value is 192.168.0.50.
- UMIP: Acronym for "Update My IP". With the activation of this function, it is allowed to communicate with the REMOTE card of the central from the web "www.l-remote.com" automatically without needing to know the IP address of the server / router.
- SERIAL NUMBER: It is the serial number of the REMOTE card needed to identify it on the web "www.l-remote.com".

### 3.2.3.10.- Stop Sounder Function.

This is option 9 of the SYSTEM CONFIGURATION menu. Within this menu we have the following options:

- ACTIVATION:
  - CONTINUOUS: "Stop Sounder" continues active after re-start up of the control panel.
  - RESET: "Stop Sounder" is automatically deactivated after re-start up of the control panel.
- PERFORMANCE:
  - CONTINUOUS: "Stop Sounders" continues active although new signal alarm arrives to control panel.
  - EVENT: "Stop Sounders" is deactivated when new signal alarm is received to control panel.
- VIEW SET UP:
  - It is shown selection of "ACTIVATION" and "PERFORMANCE".

## 4- Set-up.

### 4.1- Prior verifications.

Prior to putting the C-Lyon digital system installation into operation, we must assure ourselves that the installation is totally completed and we have all the data for its correct programming. For this it is necessary to verify that the points shown below have been completed:

- To have a 110~230V power source available dedicated to the fire protection system and that it is live 24 hours a day, seven days a week. (see chapter 2.1)
- To have a set of two 12V batteries with a capacity between 7 and 24Ah depending on the number of loops and load connected to the control panel. (to see chapter 2.3.1)
- To verify that all the elements are connected to the installation.
- To verify that there are no installation elements left unconnected or with connection errors that could cause faults when putting into operation or deterioration of the C-Lyon digital system elements.
- Do not remove the covers until the installation is finished and clean.
- To have a list with the total of connected elements of each type in each loop, see example in the following table.

LOOP: 1	
TYPE	AMOUNT
A30XHA	15
A30XVA	2
A30XHTCA	5
PUC-AY	10
SIRAY	1
MDAXY	6
MSTAY	1
KMAY	3
MYOA	1
<b>TOTAL</b>	<b>44</b>

- To have a list for each loop with the location, type and programming number of each element, (sensor, button, relay module, technical signals module, analogue sirens, master module). This programming number goes from 1 to 65533, see example in the following table:

Loop: 01				
POINT	Prog. No.	Label	Type	Notes
1	12757	ROOM 101	A30XHA	
2	12432	ROOM 102	A30XHA	
3	4767	BUTTON P1	PUCAY	
4	6982	CORRIDOR P1	KMAY	

In this way with the lists made on-site, that are completed with the listings of relay activation and with the relationship of alarm zones, it is possible to undertake the system programming working with an external keyboard, on the control panel's own keypad or much more easily using the **I-Link** program on a PC that will later download to the control panel.

#### 4.2- Supply.

**NETWORK:** The power to the input terminals will be 110~230V +/- 10% - 50-60 Hz

**Attention: Connect the EARTH cable, ensuring that the positions of the neutral line and phase are correct**

**BATTERIES:** Connect the two elements in series (**Watch out for the polarity**). In the presence of network power the battery terminals will have between 24 and 27 V DC.

The 110~230V power supply will be connected to the **C-Lyon** control panel and then the batteries. The green power supply LED on the front of the control panel must light and the initialisation texts must be seen as indicated in section 3.2.1.1.

### 4.3- Loops and relays

The loops will be put into operation one by one. Once the loop cables are connected to the corresponding driver, proceed with the element search as described in section 3.2.3.4.1. or in the element Configuration Manual.

When the search is completed check the number of elements found by the control panel against the data taken previously, see section 4.1.

- If the number found is the same, it means that all the elements are correctly connected to the Control Panel **C-Lyon** system loop.
- If the number found is higher it means that there must be more elements installed in the loop. You must update the information about them - programming numbers, labels - to be able to complete the putting on operation.
- If the number found is lower, it means that fewer elements have been installed in the loop; there are unconnected or not assembled loop elements. Review the whole loop installation reviewing all the connections and counting the installed elements.

Once any problems in the system have been resolved, the loop element search must be repeated. If a correct result is obtained, the entire process described above can be repeated for another system loop.

Next, one must proceed with the allocation of previously chosen programming numbers to the loop elements, see section 4.1. For this they will be entered into the control panel by means of its keys (see section, 3.2.3.4.1 or elements Configuration Manual), a PC keyboard (see section, 3.2.3.4.1 or Element Configuration Manual) or by means of a computer, (see I-Link Manual).

Also a name can be assigned to each loop element, called a label. It can be done from the control panel keys, (see section 3.2.3.3 or Element Configuration Manual), a PC keyboard (see section 3.2.3.3 or Element Configuration Manual) or by means of a computer, (see I-Link Manual).

If the control panel has relay modules (MDA1Y and MDA2Y) and loop sirens (SIRAY / SIRAYL), one will proceed to the configuration of such depending on the elements that must activate them, from the control panel keys, (see section, 3.2.3.4.2 or Element Configuration Manual), a PC keyboard (see section, 3.2.3.4.2 or Element Configuration Manual) or by means of a computer, (see I-Link Manual).

Optionally the Alarm Zones can be configured from the power station, (see section, 3.2.3.4.3 or Element Configuration Manual), a PC keyboard (see section, 3.2.3.4.3 or Element Configuration Manual) or by means of a computer, (see I-Link Manual).

Once the previous steps are complete we must verify that the programming performed is correct. For this we must monitor all the elements in all the loops of the control panel. This will be done from the control panel keys, (see section 3.2.2.4 or Element Configuration Manual), a PC keyboard (see section 3.2.2.4 or Element Configuration Manual).

During the startup process, the control panel may display various types of faults. For the C-Lyon digital control panel to work correctly, these faults must be resolved. For this, consult section 4.4 which describes the main faults, the causes of them and the action to be taken to resolve them.

## 4.4- Faults

### 4.4.1.- FAULTS IN CONTROL PANEL STARTUP

**THE CONTROL PANEL DOES NOT TURN ON (POWER SUPPLY AND BATTERY leds off, display shows nothing)**

<b>Cause</b>	Neither the 110~230V supply nor the batteries are providing the correct voltage to the panel.
<b>Solution</b>	Check that there is 110~230 V mains voltage in the terminal strip for connecting the AC source. Connect fully charged 24 V batteries (between 24 V and 28V).

### 4.4.2.- POWER SUPPLY FAULTS

<b>MAINS VOLTAGE DROPS (110~230V voltage does not reach the power source)</b>	
<b>Cause</b>	110~230V voltage does not reach the power source.
<b>Solution</b>	Check that there is 110~230V mains voltage in the terminal strip for connecting the A.C. source. The green led of the A.C. source must be lit. Check the status of the power supply fuse (8 Amps). (See chapters 2.2.1 and 2.2.3)

<b>MAINS VOLTAGE TOO HIGH</b>	
<b>Cause</b>	110~230V power supply is outside the permitted range.
<b>Solution</b>	Check that there is 110~230V mains voltage in the terminal strip for connecting the A.C. source. The green led of the A.C. source must be lit. (See chapters 2.2.1 and 2.2.3)

<b>NO BATTERY (The battery is not connected to the control panel)</b>	
<b>Cause</b>	Either the battery is not connected to the control panel or it is connected incorrectly.
<b>Solution</b>	Check that the batteries are correctly connected to the control panel, and check the status of the battery output fuse (5 Amps). Carefully examine the battery polarity and check that they are connected in series. For normal operation, the voltage in the battery output, when they are connected, should be between 22 V and 28 V. (See chapter 2.3.1)

<b>BATTERIES OVERLOADED (The batteries do not accept a charge)</b>	
<b>Cause</b>	The batteries have reached the end of their useful life.
<b>Solution</b>	Replace the set of batteries with new ones. For normal operation, the voltage in the battery output, when they are connected, should be between 22 V and 28 V. (See chapter 2.3.1)

<b>BATTERIES DISCHARGED (The batteries are not charged)</b>	
<b>Cause</b>	The batteries are not charged, or they are not connected correctly.
<b>Solution</b>	Check that the two 12 V batteries are connected in series, and wait for about 12 hours for them to finish charging. If the fault persists, replace the batteries with new ones. For normal operation, the voltage in the battery output, when they are connected, should be between 22 V and 28 V. (See chapter 2.3.1)

<b>CHARGER FAULT (The battery charger doesn't work)</b>	
<b>Cause</b>	The battery charger does not charge the batteries This message is associated with faults mentioned above, such as: MAINS VOLTAGE DROP, NO BATTERY, BATTERIES OVERLOADED and BATTERIES DISCHARGED. This message is displayed 4 minutes after the fault occurs.
<b>Solution</b>	Check the batteries connections and status as indicated above. If this fault is indicated, but there is no other associated message, checks the battery charger fuse (1 Amp). (See chapters 2.2.1, 2.2.3 and 2.3.1)

<b>30V FAULT (There is no 30V voltage at the 30V output from the Power Source)</b>	
<b>Cause</b>	The fuse for this output has blown due to a short circuit or excessive power consumption.
<b>Solution</b>	Check the connections for the 30V output and check how many elements, such as repeaters, electromagnets, etc. are connected to it, in order to ensure that the maximum permissible power consumption is not exceeded. (See chapters 1.5.4.1 and 2.2.3)

<b>RELAY OPEN CIRCUIT:01 (Open circuit for the S1 General Sounder relay)</b>	
<b>Cause</b>	There is a lack of continuity between the output of the S1 General Sounder relay and the end-of-line resistance.
<b>Solution</b>	Check that S1 General Sounder output is correctly connected to the sounders connected to it, check that the end-of-line resistance (4K7) and check the supervision diodes are correctly mounted (see chapters 2.3.3.1 and 2.3.3.2). Check the status of the S1 output fuse (2 Amps). To operate correctly, the S1 General Sounder's output voltage must be between -10V and -18V when in standby and between 24V and 29V when activated.

<b>RELAY SHORT-CIRCUITED:01 (Short circuit for the S1 General Sounder relay)</b>	
--	--

<b>Cause</b>	There is a short circuit between the output of the S1 General Sounder relay and the end-of-line resistance.
<b>Solution</b>	Check that S1 General Sounder output is correctly connected to the sounders connected to it, check that the end-of-line resistance (4K7) and check the supervision diodes are correctly mounted (see chapters 2.3.3.1 and 2.3.3.2). To operate correctly, the S1 General Sounder's output voltage must be between -10V and -18V when in standby and between 24V and 29V when activated.

### 4.3.- LOOP FAULTS

#### ELEMENT NOT RESPONDING

<b>Cause</b>	An element in the loop has stopped working.
<b>Solution</b>	Check that the element has not been removed from the installation, check that the element is correctly connected and that the loop voltage reaching it is between 22V and 35V. Also check that it has not been affected by external agents such as water leaks, etc. If this fault affects several elements, check whether they are all between the same two insulators. If this is the case, check that section of the installation, as there must be a short circuit in the wiring.

#### EXCESSIVE POWER CONSUMPTION

<b>Cause</b>	The loop is overloaded or has a short circuit; the voltage in the loop is below 22V.
<b>Solution</b>	Check the wiring for the affected loop, check for possible short circuits, and check whether there are elements connected to the loop that should not be directly connected to it, such as: conventional detectors, end-of-line condensers or resistances, electromagnets, sounders, etc. Also check that it has not been affected by external agents such as water leaks, etc. Once the original cause of the fault has been located and resolved, wait 5 minutes before resetting the incident in the control panel, since the protection elements need to cool down. For normal operation, the voltage in the loop should be between 22V and 35V.

#### OPEN LOOP

<b>Cause</b>	The loop is no closed correctly.
<b>Solution</b>	Review the wiring and the connection of the affected loop.

#### OPEN CIRCUIT IN MASTER (Open Circuit in the K MAY master for conventional detectors)

<b>Cause</b>	There is a lack of continuity in the wires for the line of slaves from the K MAY to the end of the line. The end-of-line is not mounted.
<b>Solution</b>	Check that the K MAY is correctly connected to the detectors and manual call points which are connected to it. Check that the end-of-line 10uF-63V condenser is correctly connected, and with the right polarity (see chapter 1.5.3.1). To operate correctly the K MAY's output voltage should be between 18V and 21V.

#### SHORT CIRCUIT IN MASTER (Short Circuit in the K MAY master for conventional detectors)

<b>Cause</b>	There is a short circuit in the connections from the K MAY to the end of the line.
<b>Solution</b>	Check that the K MAY is correctly connected to the detectors and manual call points which are connected to it. Check that the end-of-line 10uF-63V condenser is correctly connected, and with the right polarity, and check that the slave manual call points are connected with the correct polarity (see chapter 1.5.3.1). To operate correctly the K MAY's output voltage should be between 18V and 21V.

<b>RELAY OPEN CIRCUIT 01</b> (Open circuit for the relay 1 of the MDA1Y, MDA2Y or MYOA)	
<b>Cause</b>	There is a lack of continuity between the output of the relay 1 of the MDA1Y, MDA2Y or MYOA and the end-of-line resistance.
<b>Solution</b>	Check that the MDA1Y, MDA2Y or MYOA is correctly connected to the sounders connected to it, check that the 33 K $\Omega$ end-of-line resistance and the supervision diodes are correctly mounted (see chapters 1.5.3.2, 1.5.3.3 and 1.5.3.7). Check the status of the fuse protecting the module. To operate correctly, the output voltage of the relay 1 of the MDA1Y, MDA2Y or MYOA must be between -2 V and -7,8 V when in standby and between 24 V and 29 V when activated.

<b>RELAY SHORT CIRCUIT 01</b> (Short circuit for the relay 1 of MDA1Y, MDA2Y or MYOA)	
<b>Cause</b>	There is a short circuit between the output of the relay 1 of the MDA1Y, MDA2Y or MYOA and the end-of-line resistance.
<b>Solution</b>	Check that the MDA1Y or MDA2Y is correctly connected to the sounders connected to it, check that the 33 K $\Omega$ end-of-line resistance and the supervision diodes are correctly mounted (see chapters 1.5.3.2, 1.5.3.3 and 1.5.3.7). To operate correctly, the output voltage of the relay 1 of the MDA1Y, MDA2Y or MYOA should be between -2 V and -7,8 V in standby and 24 V to 29 V when activated.

<b>RELAY OPEN CIRCUIT 02</b> (Open circuit for the relay 2 of the MDA2Y)	
<b>Cause</b>	There is a lack of continuity between the output of the relay 1 of the MDA2Y and the end-of-line resistance.
<b>Solution</b>	Check that the MDA2Y is correctly connected to the sounders connected to it, check that the 33 K $\Omega$ end-of-line resistance and the supervision diodes are correctly mounted (see chapter 1.5.3.2). Check the status of the fuse protecting the module. To operate correctly, the output voltage of the relay 2 of the MDA2Y must be between -2 V and -7,8 V when in standby and between 24 V and 29 V when activated.

<b>RELAY SHORT CIRCUIT 02</b> (Short circuit for the relay 2 of the MDA2Y)	
<b>Cause</b>	There is a short circuit between the output of the relay 2 of the MDA2Y and the end-of-line resistance.
<b>Solution</b>	Check that the MDA2Y is correctly connected to the sounders connected to it, check that the 33 K $\Omega$ end-of-line resistance and the supervision diodes are correctly mounted (see chapter 1.5.3.2). To operate correctly, the output voltage of the relay 2 of the MDA2Y must be between -2 V and -7,8 V when in standby and between 24 V and 29 V when activated.

<b>24V RELAY</b> ( 24 V Fault in module MDA1Y, MDA2Y or MYOA)	
<b>Cause</b>	The 24 V voltages do not reach the module from the power supply's 30 V output, which may be from the control panel or from an auxiliary external power source.
<b>Solution</b>	Check the connections for the 30V line from the control panel's power source, or auxiliary external power source, to the 24 V input to the MDA1Y, MDA2Y or MYOA module, (see chapters 1.5.3.2, 1.5.3.3 and 1.5.3.7). To operate correctly, the 24 V voltage input to the modules should be between 20 V and 29 V.

<b>OPEN CIRCUIT 01</b> (Open line in MSTAY input)	
<b>Cause</b>	There is a lack of continuity between the entrance 1 of the MSTAY and the end of line resistance.
<b>Solution</b>	Verify the correct connection between the MSTAY and the elements connected to it, verify the end of line resistance, 33 K $\Omega$ (see 1.5.3.4 chapter). The tension of entrance 1 of the MSTAY for a correct operation must be included between -5 V and -7 V in rest.

<b>SHORT CIRCUIT 01</b> (Short line in MSTAY input)	
---	--

<b>Cause</b>	There is a short circuit between the entrance 1 of MSTAY and the end of line resistance.
<b>Solution</b>	Verify the correct connection between the MSTAY and the elements connected to it, verify the end of line resistance, 33 K $\Omega$ (see 1.5.3.4 chapter). The tension of entrance 1 of the MSTAY for a correct operation must be included between -5 V and -7 V in rest.

<b>OPEN CIRCUIT 02 (Open line in MSTAY or MYOA input 2)</b>	
<b>Causa</b>	There is a lack of continuity between the entrance 2 of the MSTAY or MYOA and the end of line resistance.
<b>Solución</b>	Verify the correct connection between the MSTAY, MYOA and the elements connected to them, verify the end of line resistance, 33 K $\Omega$ (see 1.5.3.4 and 1.5.3.7 chapters). The tension of entrance 2 of the MSTAY for a correct operation must be included between -5V and -7 V in rest.

<b>SHORT CIRCUIT 02 (Short line in MSTYA or MYOA input 2)</b>	
<b>Cause</b>	There is a short circuit between the entrance 2 of the MSTAY or MYOA and the end of line resistance.
<b>Solution</b>	Verify the correct connection between the MSTAY, MYOA and the elements connected to them, verify the end of line resistance, 33 K $\Omega$ (see 1.5.3.4 and 1.5.3.7 chapters). The tension of entrance 2 of the MSTAY for a correct operation must be included between -5V and -7 V in rest.

<b>TECHNICAL FAULT (IN2 input to the MSTAY has been activated)</b>	
<b>Cause</b>	A signal which is external to the digital detection system has activated the MSTAY IN2 input.
<b>Solution</b>	This is not a fault in the digital detection system; in fact this is how it should normally work. Check the operating status of the devices connected to the MSTAY (IN2).

<b>DIRTY SENSOR</b>	
<b>Cause</b>	The permitted level of dirt has been exceeded on the sensor (A30XHA, A30XHA-S and A30XHTCO), 100% in the monitoring screen, the sensor must be cleaned.
<b>Solution</b>	Clean the sensor using compressed air reset the fault and monitors the element, checking that the readings are below 5. If the levels are higher or the dirty sensor fault is repeated, cleaning it has not been sufficient and it is recommended that the sensor is replaced with a new one.

#### 4.4.4.- OTHER FAULTS

<b>ELEMENT NOT FOUND (In the monitoring screen)</b>	
<b>Cause</b>	The loop point indicated cannot be found by the control panel.
<b>Solution</b>	The element being monitored either has not been installed or else its programming number has not been assigned. Check the element's configuration.

<b>REPEATER: XX IS NOT COMMUNICATING</b>	
<b>Cause</b>	There is a failure in communication with the indicated repeater.
<b>Solution</b>	Check the repeater's connection to the control panel, check for short circuits and broken wires, measure the repeater's supply voltage to check that it is between 24V and 30V. Check that the repeater's number is correctly configured, making sure that the number configured in the control panel is the same as the repeater's number. (see chapter 3.2.3.9)

<b>CONTROL PANEL: XX IS NOT COMMUNICATING</b>	
<b>Cause</b>	There is a failure communication with the indicated control panel.
<b>Solution</b>	Check the connection of the control panel with the main control panel; check short circuits, cut cables, check the correct operation of the control panel (see 1.5.5 chapter). Check that do not exist two or more control panels with the same number.

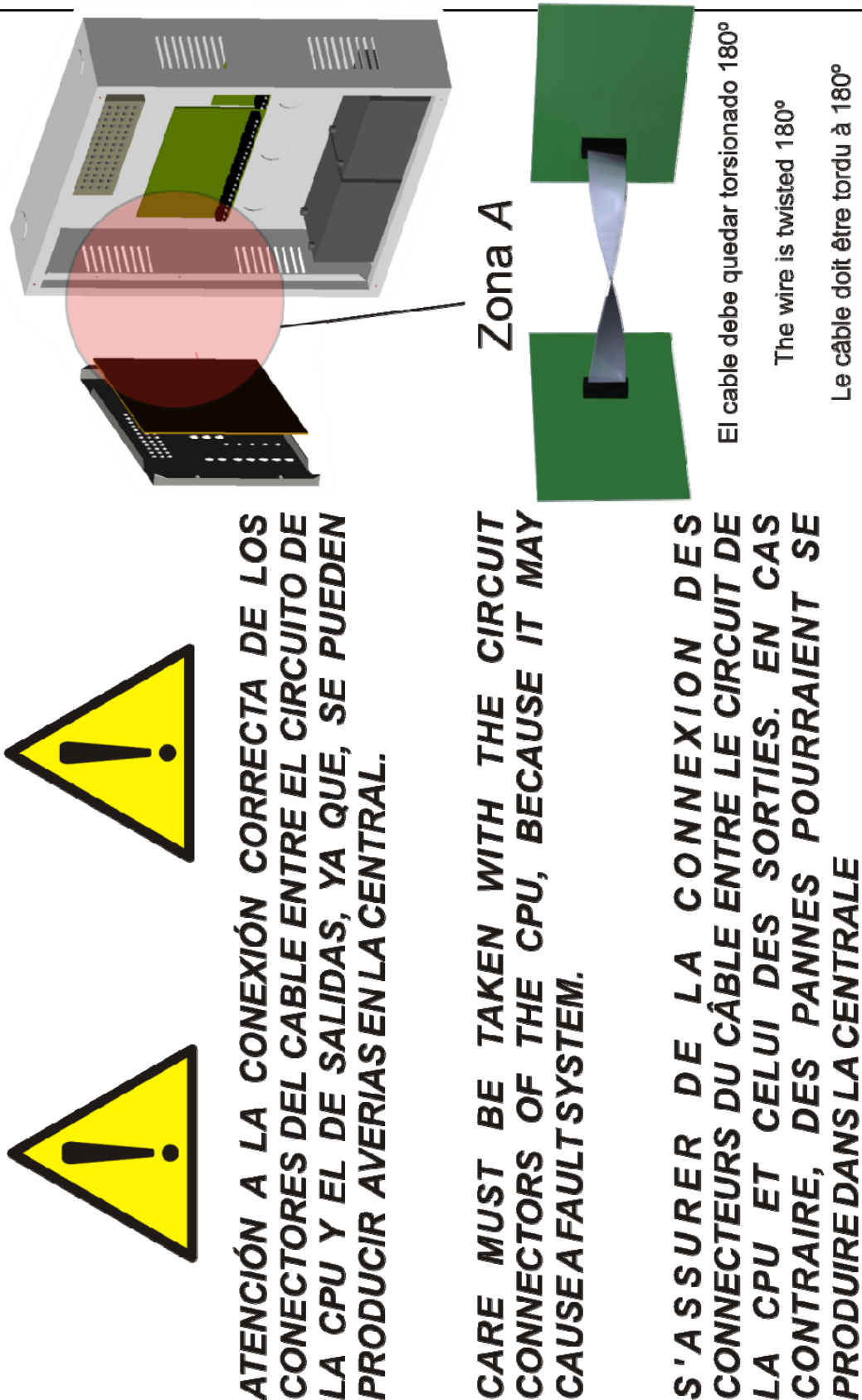

**Figura 24.** Conexión conector CPU / CPU connector connexion / CPU  
Connexion connecteur

**NOTE:**

COFEM S.A. reserves the right to make changes due to typographical errors, inaccuracies in the current information or program and/or equipment improvements at any time and without prior notice



## Annex 1: Use of the Control Panel LYON / C-LYON / ZAFIR system

### 1. What is a control panel LYON / C\_LYON /ZAFIR SYSTEM?

The LYON / C\_LYON / ZAFIR system is a FIRE detection system that combined with detectors and corresponding modules, is capable of quickly detecting the early signs of a fire, issuing a warning of the event and acting on various elements, such as emergency exit doors, acoustic fire alarms or crossed outputs.

### 2. Front panel of the system

This is what the control panel of the centralised LYON system looks like:

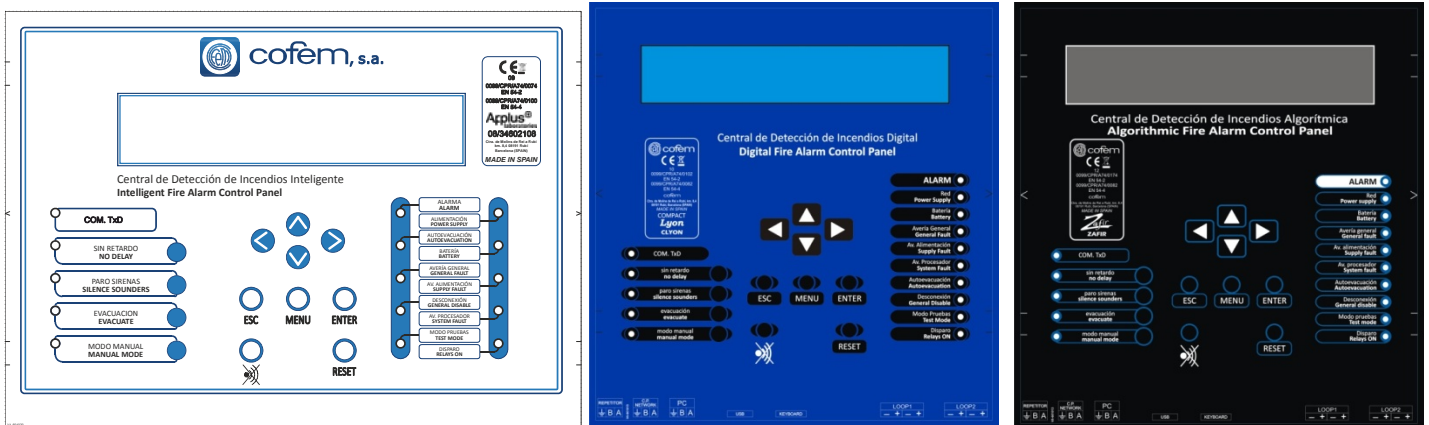

The **keys** enable action to be taken via the control unit, while the **luminous indicators (LEDs)** and the **screen** provide information about the system status.

### 3. What happens if the buzzer sounds?

The buzzer or acoustic warning emits an intermittent alarm if any of the following situations arise:

1. A **fire alarm** has been generated.
2. A relay has been **actuated**.
3. A **fault** has occurred in the detection system.

**To stop the buzzer, press this key:**



**IMPORTANT: THE INCIDENT must always be CHECKED when this key is pressed.**

### 4. Checking the incident

Having stopped the buzzer, the user must check the incident. For this purpose, the control unit incorporates a screen to display information and various luminous indicators that provide details regarding the incident that has occurred. The options are: an **ALARM**, an **ACTUATION** or a **FAULT**.

In the event of several types of incident occurring simultaneously, the display can be toggled by pressing the **ENTER** key. The information displayed on the screen can be expanded using:

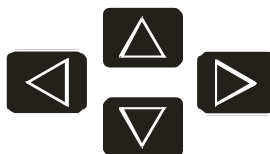

If the incident in question is an **ALARM**, the user must verify whether it is real. If so, the order to evacuate can be given. Beforehand, **the keypad must be enabled** and also if any of the keys on the control panel are pressed, except for the **buzzer** (the control panel requests a code to be entered):

To enable the keypad, the access code must be entered by using the (**▲▼◀▶**) keys:

**The access code is:**  
**27**  
**(This must be confirmed with the ENTER key).**

This operation must be performed each time an access code is requested. Once the code has been entered, all the keys on the control panel can be used.

## 5. Evacuation

This function can be performed once the **keypad has been enabled** and by pressing the evacuation key.



**IMPORTANT:** This must be confirmed with the **ENTER** key

This function activates all **sirens** and **switches** in the system. This is also shown by lighting the luminous indicator.

## 6. SILENCE SIRENS

When required, this function enables the sirens to be silenced. The **keypad** must be **enabled** and it is performed by pressing the SILENCE SOUNDERS key:



**IMPORTANT:** while the luminous indicator is lit, the system's sirens will **NEVER** be activated.

## 7. RESET EVENTS

In the case of a false alarm, the user must **Reset** the alarm. With the **keypad enabled**, select the alarm to be reset and press the **reset** key:



**IMPORTANT:** when an alarm is reset, this must be confirmed with the **ENTER** key

If the incident is a **FAULT**, this must also be **Reset** following the exact same process as explained above. If the **FAULT** reoccurs, contact the technical service.

**DISCONNECT the 110~230V POWER supply and the BATTERIES before accessing the interior of the control unit.**

## Annex 2: Elements configuration Lyon / C-Lyon / Zafir

### 1. Introduction

The steps necessary to configure the Analogue Control Panel LYON are given below.

The analogue system includes the following elements:

<b>Analogue detectors</b>		
	Optical sensor	<b>A30XHA</b>
	Heat sensor	<b>A30XTA</b>
	Multi-sensor	<b>A30XHTCO</b>
<b>Analogue key</b>		
		<b>PUCAY</b>
<b>Master module</b>		
		<b>KMAY</b>
<b>Relay modules</b>		
	1 relay	<b>MDA1Y</b>
	2 relays	<b>MDA2Y</b>
<b>Technical signals module</b>		
		<b>MSTAY</b>
<b>Relay and Technical signal module</b>		
		<b>MYOA</b>
<b>Loop isolator base</b>		
		<b>KABY</b>
<b>Analogue siren</b>		
		<b>SIRAY / SIRAYL</b>

Each of these elements has a programming label. This number is assigned at the factory. When an element search operation is conducted using the control unit, it finds all the loop elements, memorising the type of element and the assigned programming number.

The basic purpose of this procedure is that, by conducting this search, all these numbers can be passed to the control unit memory and for them to be assigned to the loop where the search was conducted.

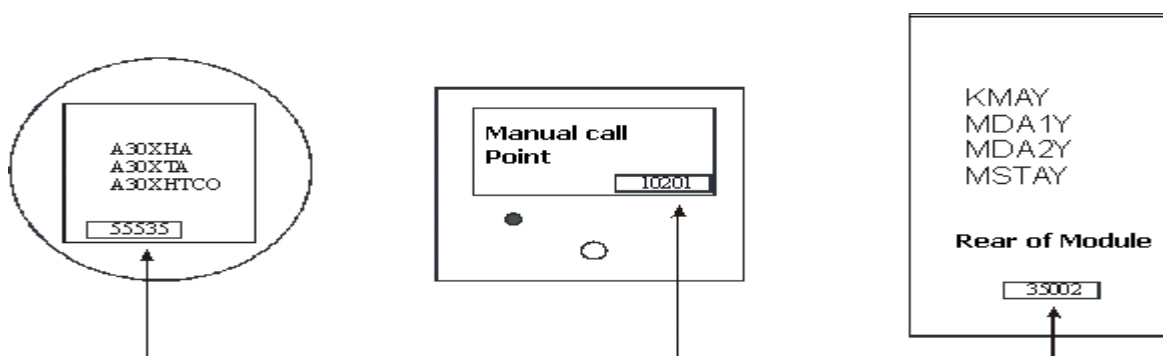

**NOTE:** Before assigning a point, it is highly advisable to obtain the programming lists with all the data.

### 2. Keypad access

If the keypad has not been enabled, the only key that will work is the stop **BUZZER** button (*in the event of any new incidents, the buzzer will be activated again*). The LYON / / C-LYON / ZAFIR system provides several different access levels to the various internal functions. The first level of access controls the use of the keypad.

When any of the keys on the control panel are pressed, an access code will be requested:

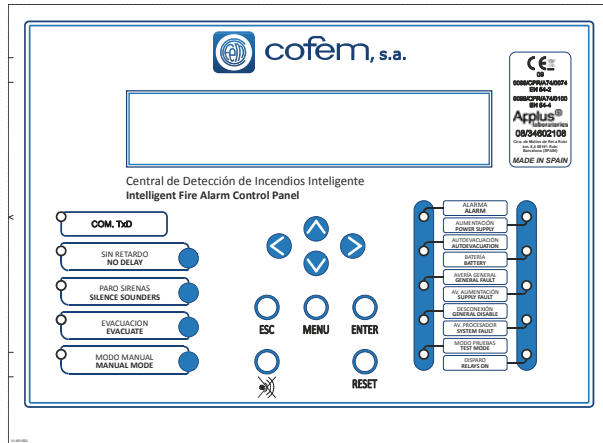

**AN ACCESS CODE WILL BE REQUESTED N° 27**

**IMPORTANT:** If no key is pressed within a period of 30 seconds, the keypad is blocked and the previous step must be repeated in order to continue using the keypad.

As soon as keypad access has been provided, all keys can be used immediately.

**3. Configuration of points in a loop**

Pressing the menu button will show the main menu on the display.

KEYS FOR NAVIGATING THE MENUS



ESCAPE KEY (Return to previous screen)



ENTER KEY (Confirm menu options)

By using the arrow keys, the menu options below will be displayed:

- 1 Monitor
- 2 Logical relay activation
- 3 General relays
- 4 System configuration
- 5 Elements/zones in/out of service
- 6 System test
- 7 Welcome message
- 8 General reset

### 3.1. System Programming

By selecting option **4 System Configuration**, the access code for level 3 will be requested. Enter the code and confirm with the **ENTER** key.

**AN ACCESS CODE WILL BE REQUESTED N° 9000**

The following menu will appear on the display:

- 1 Review history
- 2 Label elements
- 3 Configure
- 4 Update date and time
- 5 Day/Night times
- 6 Activate test/normal mode
- 7 Language menu
- 8 Communications

### 3.2. Configure

Select option **3 Configure**, and confirm with the **ENTER** key.

The following menu with 6 options will appear on the display:

- 1 Loop Configuration
- 2 Configure Logical Relays
- 3 Configure Alarm Zones
- 4 Configure Element Sensitivity
- 5 Additional Passwords
- 6 Configure Auto Evacuation

### 3.3. Configure Loop

By selecting option **1 Loop Configuration** the option will be the first to appear. Confirm with the **ENTER** key. You will be asked for the number of the loop to be configured.

The following menu with 3 options will appear on the display:

- 1 Sensitivity of a type
- 2 Flashing
- 3 Point configuration

### 3.4. Loop Configuration

**The first step is to configure the elements of the loop so that the control unit recognises all the Elements that are connected to each of the loops.**

By selecting option **3 Point Configuration** the option will be the first to appear. Confirm with the **ENTER** key.

The following menu with 7 options will appear on the display:

- 1 View loop information
- 2 Search for loop element
- 3 Assign a number to an element
- 4 Automatic loop configuration
- 5 Delete point
- 6 Delete programming number
- 7 Delete loop element

By selecting option **2 Search for loop element** the option will be the first to appear. Confirm with the **ENTER** key.

This function passes all the programming numbers to the control unit memory and, after a few seconds, the total number of elements that have been configured in the loop will appear on the display and how many there are of each type. This search will take approximately 80 seconds.

Check that the information displayed is correct.

#### Important note:

This step must be performed for each of the installed loops. It must be done even if there are no elements connected to the loop.

### 3.5. Assign a number to Point

By selecting option **4 assign a number to an element** the option will be the first to appear. Confirm with the **ENTER** key.

This option assigns a loop and an order number within the loop to each element.

**Important:**

In order to proceed with this operation, the installer must have made written note of the programming number of each of the detectors and the loop in which they are installed.

Firstly, you will be asked for the programming number of the corresponding Point, confirmed with the **ENTER** key. Secondly, you will be asked for the assigned Point number, confirmed with the **ENTER** key.

### 4. Programming verification process

It is always recommended to check that programming has been performed correctly.

• **Monitor**

**This function is number 1 on the first menu. Select with the ENTER key.**

Firstly, you will be asked for the number of the loop and then the programming number of the element.

B: 1	P: 7	NS: 55463	TYPE: A30XTA
LOOP: 001	ADDRESS: 001	S. Num.: 55463	
Values: [022 022 022 022]	Last: 000		
Dirt: 000%	Average: - - -	Sensitiv: MED	

Check that the information shown is correct.

With the (← →) arrow keys, it is possible to change from one point to another.

With the (↑ ↓) arrow keys, it is possible to change from one loop to another

### 5. Configure Zones

The purpose of an alarm zone is to provide more complete information and to achieve greater speed when locating an element with an alarm. The aim of a zone is to group together detectors that are located in the same area.

When an incident is detected by the control unit, pressing the (→) key will display the label of the zone to which point belongs.

ALARMS	C: B: Pt:
01 > Z: 001 LABEL	01 01 006
	<< 01 / 02

Alarm zone label →

In order to configure alarm zones, it is necessary to follow the following steps:

Menu (access code 27) → **4. System configuration** (access code 9000) → **3 Configure** → **3 Configure Alarm Zones**.

You will be asked for the number of the zone to configure. Enter the number and the following menu will appear:

- 1 Configure zone
- 2 Modify Lists
- 3 Delete zone
- 4 Label
- 5 View configuration





**FABRICANTE DE PRODUCTOS CONTRA INCENDIOS - FIRE PROTECTION MANUFACTURER**  
**FABRICANTS DE PRODUITS CONTRE INCENDIES**  
 Ctra. de Molins de Rei a Rubí, Km. 8,4 - 08191 RUBÍ (Barcelona) SPAIN

<b>Comercial</b> <i>Commercial</i>	+34 935 862 690	comercial@cofem.com cofem@cofem.com
<b>Ventas</b> <i>Sales</i>	+34 935 862 690	ventas1@cofem.com ventas2@cofem.com
<b>Atención Técnico Comercial</b> <i>Technical &amp; Commercial Service</i>	+34 902 448 811	sat1@cofem.com sat2@cofem.com
<b>S.A.T.</b> <i>T.A.S</i>	+34 935 862 692	tecnic@cofem.com
<b>Compras</b> <i>Purchase</i>	+34 935 862 693	compras@cofem.com
<b>Export</b> <i>Export</i>	+34 935 862 694	export@cofem.com
<b>Fax pedidos</b> <i>Orders Fax</i>	+34 902 338 811	
<b>Fax general</b> <i>Fax</i>	+34 936 999 261	